

# Nº585

# Nº585.5

INTEGRATED AMPLIFIER OWNER'S MANUAL

mark  
levinson®  
by HARMAN

## TABLE OF CONTENTS

About This Document	2
Special Design Features	3
Setup Menu Setup Menu Navigation, Input Setup, Volume Control, Power Management, Advanced, Output	4
SSP Setup	10
Troubleshooting	12
Specifications	16

## ABOUT THIS DOCUMENT

This User Guide primarily covers the system functions and advanced options contained in your N°585 and N°585.5 Setup menus. The N°585.5 includes the Pure Path Phono module. For the purposes of this guide we will refer to the unit as the N°585 except when referencing phono features. This guide also covers setup for SSP (Surround Sound Processor) mode. These resources allow you to finely tailor the behavior and performance of the N°585 to fit your preferences and the particulars of your equipment and listening room.

Before you read this User Guide, we recommend that you thoroughly read the *N°585/N°585.5 Quick-Start Guide*, supplied with your N°585 in printed form. The *Quick-Start Guide* contains all the information you will need to unpack and place your N°585, connect it to the rest of your audio system and have a first listen.

For the sake of brevity, instructions in this guide refer only to the use of front-panel controls. Functions accomplished by using the front-panel Select knob, Setup button, and Enter button may also be accomplished using the remote-control Select +/- buttons, Setup button, and Enter button.

## SPECIAL DESIGN FEATURES

Thank you for purchasing the N<sup>o</sup>585 integrated amplifier. Combining Mark Levinson's unsurpassed analog performance with advanced digital audio capability and flexible system configuration, the N<sup>o</sup>585 pushes the reproduction of any source material to new levels of realism.

### Architecture

The foundation of the N<sup>o</sup>585 is its fully-discrete, mirror-imaged, dual-monaural analog circuitry featuring individual signal switching relays for each of its four stereo inputs: one balanced (XLR) and three single-ended (RCA). Volume controls use discrete 15-bit R-2R ladders and low-noise analog switches for the widest possible bandwidth and maximum signal integrity. The fully-differential Class A/B power stage includes an oversized 900VA toroidal transformer with individual secondary windings for the left and right channels. Each elegantly simple amplifier channel utilizes twelve output transistors and multiple smaller local capacitors, which allows them to be placed physically closer to the amplifiers for greater transient response when power is needed immediately. This robust architecture results in a conservative power rating of 200W per channel. System integration and expansion are possible using the stereo RCA preouts which can operate full-range or with an included switchable, second-order, 80Hz crossover filter allowing for seamless integration into 2.1-channel systems with powered subwoofers.

### Audio Chassis

Building upon this superb analog platform, the N<sup>o</sup>585 adds equally outstanding digital audio capability. An ESS Sabre 32-bit D/A converter with proprietary jitter elimination circuitry and fully-balanced, discrete I/V circuitry forms the heart of the digital audio processing stage. Six digital audio inputs are provided including one AES/EBU, two coaxial and two optical plus a USB audio processor capable of asynchronous data transfer of high resolution DSD and PCM files at up to 192kHz/32 bits resolution. For low-resolution audio formats, proprietary Clari-Fi™ signal processing reconstructs information and bandwidth lost in compressed file formats restoring them to higher fidelity. System integration and communication ports include Ethernet, USB, RS-232, IR input, and 12V trigger input and output. A system IR remote control is included.

### Construction

The chassis of the N<sup>o</sup>585 utilizes card-cage architecture to isolate critical low-level analog and digital circuitry from the power supplies and amplifier modules. The steel and aluminum construction features internal amplifier heatsinks and Mark Levinson's iconic black and silver anodized aluminum front panel with its intuitive twin-knob control system and unique red display.

### Features

- Modular circuit design provides isolation of critical audio circuitry subsections
- High-resolution 32-bit/192kHz D/A converter with asynchronous USB input
- Patented Clari-Fi™ signal processing for compressed audio formats
- Fully-differential, Class A/B amplifier rated at 200W into 8 ohms
- Four analog audio inputs: One balanced (XLR) and three single-ended (RCA) stereo pairs
- Six digital audio inputs: One USB, one AES/EBU, two coaxial and two optical
- Analog preouts with selectable 80Hz crossover filter for 2.1-channel capability
- System controls: Ethernet, RS-232, IR input, and 12V trigger input and output
- IR remote control
- Software update via USB flash drive or Ethernet
- The N<sup>o</sup>585 includes one phono (RCA) with grounding terminal
- The N<sup>o</sup>585.5 includes a phono stage with selectable gain, infrasonic filter, resistive and capacitive-loading settings

# SETUP MENU

This section explains the use of the Setup menus on your N<sup>o</sup>585, which allow you to customize and configure the unit.

## SETUP MENU NAVIGATION

Pressing the Setup button displays the Setup menu on the integrated amplifier's front-panel display. When the Setup menu is active, use the Select knob to scroll through options, the Enter button to select and deselect options, and the Volume knob to adjust parameters. To move back a level in the menu structure (or exit the Setup menu), press the Setup button repeatedly until the desired menu is shown in the display.

## INPUT SETUP

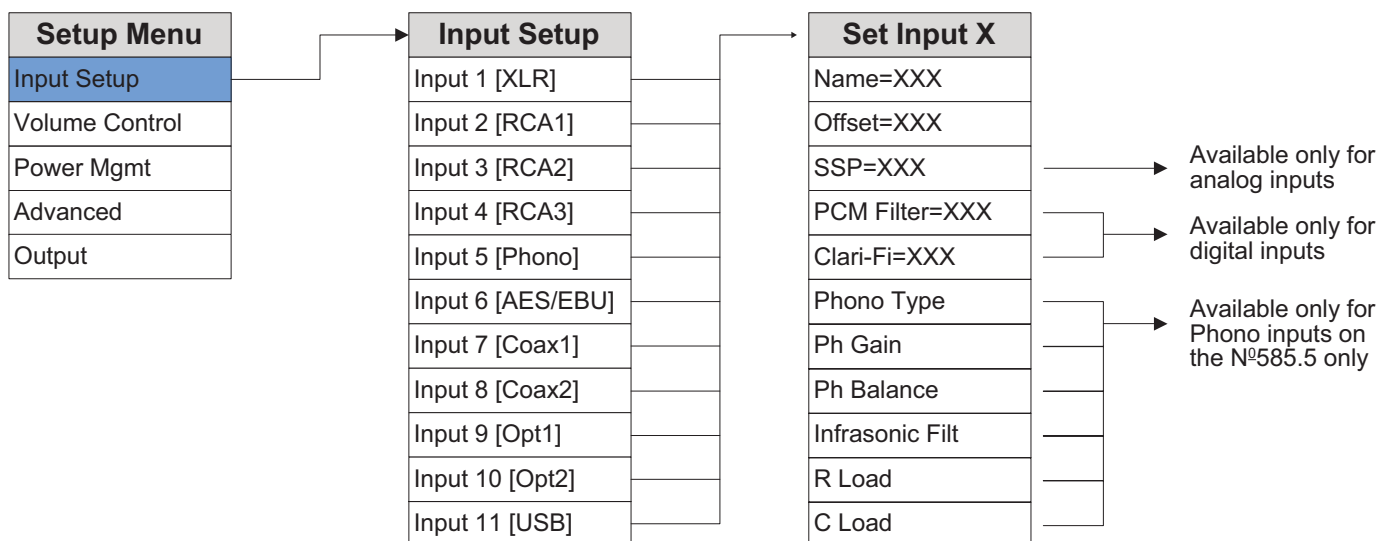

The Input Setup menu allows you to customize the following parameters for the selected input:

**The following settings are available for all inputs.**

**Name:** This option offers a choice of preset names for the selected input (CD, SACD™, DVD, Blu-ray™, DAC, EQ, Input [number], [Input type], [Input connector]. Additionally, the following special names are available for each input:

**Unused:** This option removes the selected input from the list of available inputs. The input will be skipped when selecting the active input.

**Manual Entry:** This option allows you to enter a custom name for the selected input. Use the Select knob to select the character you want to change, use the Volume control to choose from the list of available characters and press the Enter button to confirm each character. After the eighth character is entered, the new name will be saved.

Note that Input 5 is reserved for future use.

**Offset:** The output level of audio devices can vary from brand-to-brand and model-to-model, making some devices sound louder or quieter than others. The Offset adjustment lets you precisely compensate for that variance, allowing all associated devices in your system to output at a similar volume level.

The setting offers a range of -12.0dB to +12.0dB, in 0.1dB steps. Whenever an input is selected, the N<sup>o</sup>585 applies the setting of the Offset parameter to the volume level of the Speaker and Line outputs.

**SSP:** The SSP setting configures the selected input for complete integration with a multichannel surround sound processor. See *SSP Setup* on page 10 for more information. (Note: The SSP setting is only available for analog inputs.)

**The following settings are available only for the digital inputs.**

*PCM Filter:* This setting lets you set the filter characteristic for PCM content:

*Fast:* This filter has a steep roll-off characteristic that may be better suited when listening to electric or electronic music.

*Slow:* This filter has a gradual roll-off characteristic that is well suited to most types of music.

*Mphas:* This is a minimum-phase filter that may be better suited when listening to acoustic music.

Although the above descriptions are offered as a guide, feel free to set the PCM filter according to your own tastes.

*DSD Filter:* This setting lets you set the filter characteristic for DSD content. You can select from roll-offs that begin at 47kHz, 50kHz, 60kHz or 70kHz. The sonic effects of the different roll-off characteristics are subtle and will vary depending on the type of musical content, so feel free to set the DSD filter according to your individual taste.

*Clari-Fi™:* Setting this to *ON* activates the Clari-Fi circuitry for the input. Clari-Fi analyzes compressed digital audio files during playback and reconstructs much of what was lost in the compression process. The Intensity control adjusts the amount of reconstruction applied to the signal, and can be applied according to your individual taste – there is no “correct” amount.

**The following settings are available for the Phono input on the N°585.5 only.**

*Cartridge Type:* This setting enables selection of moving-magnet (MM) or moving-coil (MC) cartridge. *Resistive Loading:* this option sets moving-coil cartridges' resistive loading between 50 and 1000 ohms. *Capacitive Loading:* this option sets capacitive loading between 50 and 680 pF.

*Infrasonic Filter:* This option sets the infrasonic “rumble” filter on or off.

*Gain:* This option selects High or Low gain for the Phono input.

*Balance:* This option applies balance from -3dB to +3dB in 0.1 dB steps to the Phono input.

VOLUME CONTROL

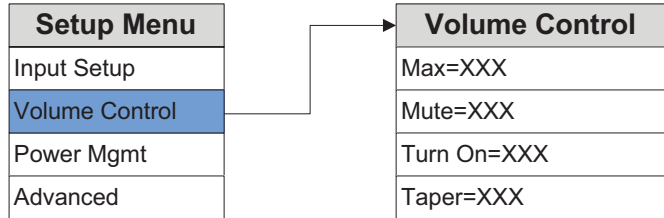

The Volume Control settings let you customize the action of the N<sup>o</sup>585's Volume and Mute functions.

*Max Vol:* This setting lets you set a maximum Speaker output and Line output volume level setting in 0.1dB increments between 40.0dB and 80.0dB. The factory default maximum volume is 80.0dB.

*Mute:* This setting lets you set the amount of Speaker output and Line output level attenuation that occurs when the Mute button is engaged, in 0.1dB increments between -10dB and -80.0dB. The factory default mute attenuation is -40dB.

*Turn On:* This setting lets you set a Speaker output and Line output volume level to which your N<sup>o</sup>585 will default every time you turn it on.

- 10.0dB – 60.0dB: Choose a turn-on volume level in 0.1dB increments between 10.0dB and 60.0dB. The factory default setting is 40.0dB.
- Last: The volume level setting from the previous time the unit was powered down is retained.

**CAUTION:** Setting the Turn On parameter to Last can result in louder-than-expected power-up volume if the N<sup>o</sup>585 was set to a high volume level setting when last powered down.

*Taper:* This setting lets you choose the desired taper for the volume control, from the following options:

Mode 1: The faster you rotate the volume knob the more quickly the volume will change. Rotating the knob slowly slows the rate the volume changes, allowing you to make very precise adjustments in the listening level.

Mode 2: Similar to Mode 1, with a "faster" response curve, with more gain change for a similar range of knob travel.

Mode 3: When increasing the volume the volume changes quickly through the low volume range, and then decelerates in the higher range, for precision adjustments. When decreasing the volume the control works in the opposite fashion, changing quickly through the high volume range and decelerating in the lower range.

## POWER MANAGEMENT

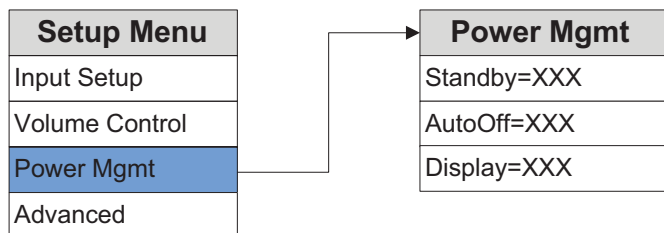

The Power Management parameters let you customize power-related functions.

*Standby:* This setting lets you set the Standby mode to one of the following options:

**Green:** This mode removes power from almost all of the N<sup>o</sup>585's circuits, allowing the unit to be activated only via an IR control signal, a 5V – 12V trigger voltage or a press of the Standby button. This mode provides maximum power conservation and is the factory-default Standby mode.

**Power Save:** This mode removes power from the N<sup>o</sup>585's audio circuits, but keeps the control circuitry powered and ready to receive commands from either the front-panel controls or the remote control. This mode provides moderate power conservation.

**Normal:** This mode shuts off the N<sup>o</sup>585's display and mutes its audio outputs, but keeps all of its control and audio circuits powered. This mode provides the least amount of power conservation but allows the N<sup>o</sup>585's audio circuits to remain warmed up to deliver optimal performance at all times.

*Auto Off:* This setting lets you engage or disengage the Auto Off function, which puts your N<sup>o</sup>585 into the Standby mode after 20 minutes of inactivity (no audio signal, and no user-control input).

*Display:* This menu gives you access to the following display-related parameters:

**Intensity:** Lets you set the brightness of your N<sup>o</sup>585's display and front-panel LEDs to High, Med, Low, or Off (which turns the display and LEDs off entirely until a control is operated). The factory default setting is High.

**Timer (only applies when the display intensity is set to Off):** Lets you choose how long the display and LEDs remain lit after the last time a control is operated. Choose from 10 seconds, 4 seconds, or 2 seconds. The factory default setting is 10 seconds.

ADVANCED

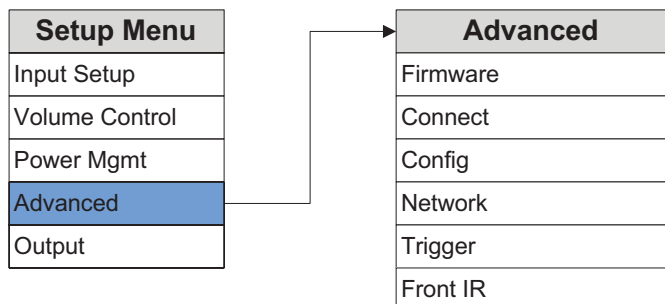

The Advanced section of the Setup menu gives you access to a range of configuration and administrative settings and functions.

**Firmware:** This menu gives you access to the following firmware-related functions:

**Ver:** Displays the version number of the currently loaded firmware. (This setting is informational only, and does not provide any user adjustments.)

**Update:** Lets you update your N<sup>o</sup>585's firmware, either from a flash drive inserted in the rear-panel USB port or from a connected computer over the Ethernet connection. (If you press Enter when ENET is selected, The N<sup>o</sup>585's display shows "Start Download" to remind you to connect via a browser and begin downloading the firmware.) To update via a flash drive:

1. Select USB and press Enter.
2. The N<sup>o</sup>585 will read the USB drive. (The display will show "Not Ready" while the drive is being read.)
3. When the N<sup>o</sup>585 finds a valid firmware file on the drive, the display will show "Downloading."
  - If the N<sup>o</sup>585 does not find a valid firmware file on the drive, the display will show "Not Available."

**Connect:** This menu lets you select the type of control connection you made to your N<sup>o</sup>585: Ethernet, or RS232.

**Config:** This menu lets you import or export Setup menu configuration settings.

**Export:** Press Enter to export all setup configuration information to a thumb drive inserted in the rear-panel USB port. This data can then be used to identically configure other N<sup>o</sup>585 units, or serve as a backup so you can easily reconfigure your N<sup>o</sup>585.

**Import:** Press Enter to import all setup configuration information from a thumb drive inserted in the rear-panel USB port.

**Lock:** Engage the Lock to prevent accidental changing of Setup menu parameters. The factory default setting is Off.

**Restore:** Lets you restore all N<sup>o</sup>585 parameters to their factory-default condition.

**Network:** This menu offers access to the following network-related parameters:

**Name: N<sup>o</sup>585\_XXXXXX:** Displays your N<sup>o</sup>585's network name (the X's represent the last six digits of the unit's unique MAC address). This setting is informational only and does not provide any user adjustments.

**DHCP:** Lets you toggle DHCP mode (network auto-configuration) on or off. The factory default behavior is On. When the mode is set to Off, you can specify static IP and Subnet addresses for your N<sup>o</sup>585. Selecting Renew (available only when DHCP is set to On) refreshes your DHCP configuration, assigning a new IP address to your N<sup>o</sup>585. This function is often useful when troubleshooting a network connection.

**Current IP:** Shows the IP address currently assigned (by DHCP or manually) to your N<sup>o</sup>585. (This setting is informational only and does not provide any user adjustments.)

**Current Subnet:** Shows the subnet address currently assigned (by DHCP or manually) to your N<sup>o</sup>585. (This setting is informational only and does not provide any user adjustments.)

**Trigger:** This setting configures how the 12V trigger relay data is sent and received. Most components require this to be set at "Normal," but some products (such as some older Mark Levinson components) require that it be set to "Pulsed."

**Front IR:** This menu allows you to turn the N<sup>o</sup>585's front IR receiver on or off. If you have connected the N<sup>o</sup>585's rear-panel IR input to an IR control device, we recommend that you set the Front IR receiver to Off to avoid interference.



## OUTPUT

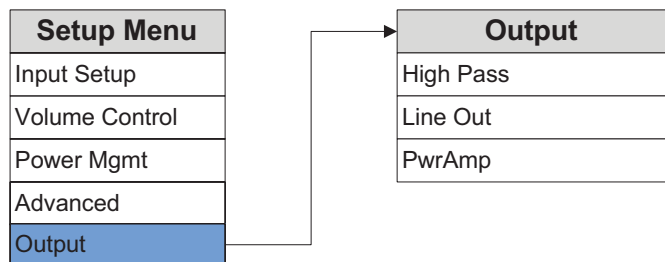

The Output section of the Setup menu lets you configure the N°585's outputs.

*High Pass:* This menu allows you to activate a 12dB/octave Butterworth 80Hz high-pass filter on the N°585's speaker outputs. If you have connected a powered subwoofer to the N°585's Line Outputs and want to restrict the low frequencies sent to your system's main speakers, set the Hi Pass filter to On.

*Line Out:* This menu lets you set the N°585's Line Outputs to Fixed or Variable:

**Fixed:** Use this setting when you have connected the Line Outputs to a recording device. The Line Outputs will remain at a fixed level regardless of the N°585's volume control level.

**Variable:** Use this setting when you have connected the Line Outputs to a powered subwoofer or to an external amplifier. The Line Output level will vary with the level of the N°585's volume control.

*PwrAmp:* This menu lets you enable or disable the N°585's power amplifier, such as when you are using your N°585 in a multi-zone system or with an upgraded power amplifier.

## SSP SETUP

In the past, the differing number of channels in each component made integration between two-channel and multichannel components difficult. Sending multichannel processor output signals to a stereo Preamplifier distorts calibrated processor output levels. Multichannel processor volume controls adjust the relative volume level of all channels in unison. However, stereo Preamplifier volume controls adjust the relative volume level of just the front left and right channels, leaving the center, surround, and subwoofer channels unaffected.

To avoid these problems when the N°585 is connected with an associated surround-sound processor, the SSP mode allows selected input sources to pass through the N°585 without interference. When SSP mode is activated the N°585 volume control is deactivated to prevent the N°585 from distorting channel balance. As a result, the processor controls the relative volume level of all channels while maintaining its calibrated output levels.

**To connect the N°585 with a surround-sound processor (see illustration on next page):**

1. Make sure the N°585 and all associated components are powered off and disconnected from electrical outlets.
2. Connect the output connectors on the surround-sound source component to the input connectors on the surround-sound processor. For example, if the source component is a Blu-ray disc player, connect it to the appropriate input connectors on the surround-sound processor.
3. Connect the front left and right output connectors on the processor to the desired input connectors on the N°585. For best performance, use balanced connections whenever possible.
4. Connect the center, surround, and subwoofer output connectors on the processor to the appropriate input connectors on the power amplifier(s).
5. Connect the N°585's speaker outputs to the system's front left and right (main) speakers.

**To activate the SSP mode for a selected input:**

**CAUTION:** Before activating the SSP mode for any input, set the associated surround sound processor volume control to a reasonable level to prevent sending dangerous signal levels to the associated loudspeakers.

1. Activate the Setup menu by pressing the Setup button.
2. Select Input Setup, and press Enter.
3. Select the input you wish to configure for SSP use, and press Enter.
4. Select SSP, and press Enter.
5. Set the SSP parameter to On.
6. Press the Setup button four times to step backward through the menu hierarchy and exit the Setup menu.

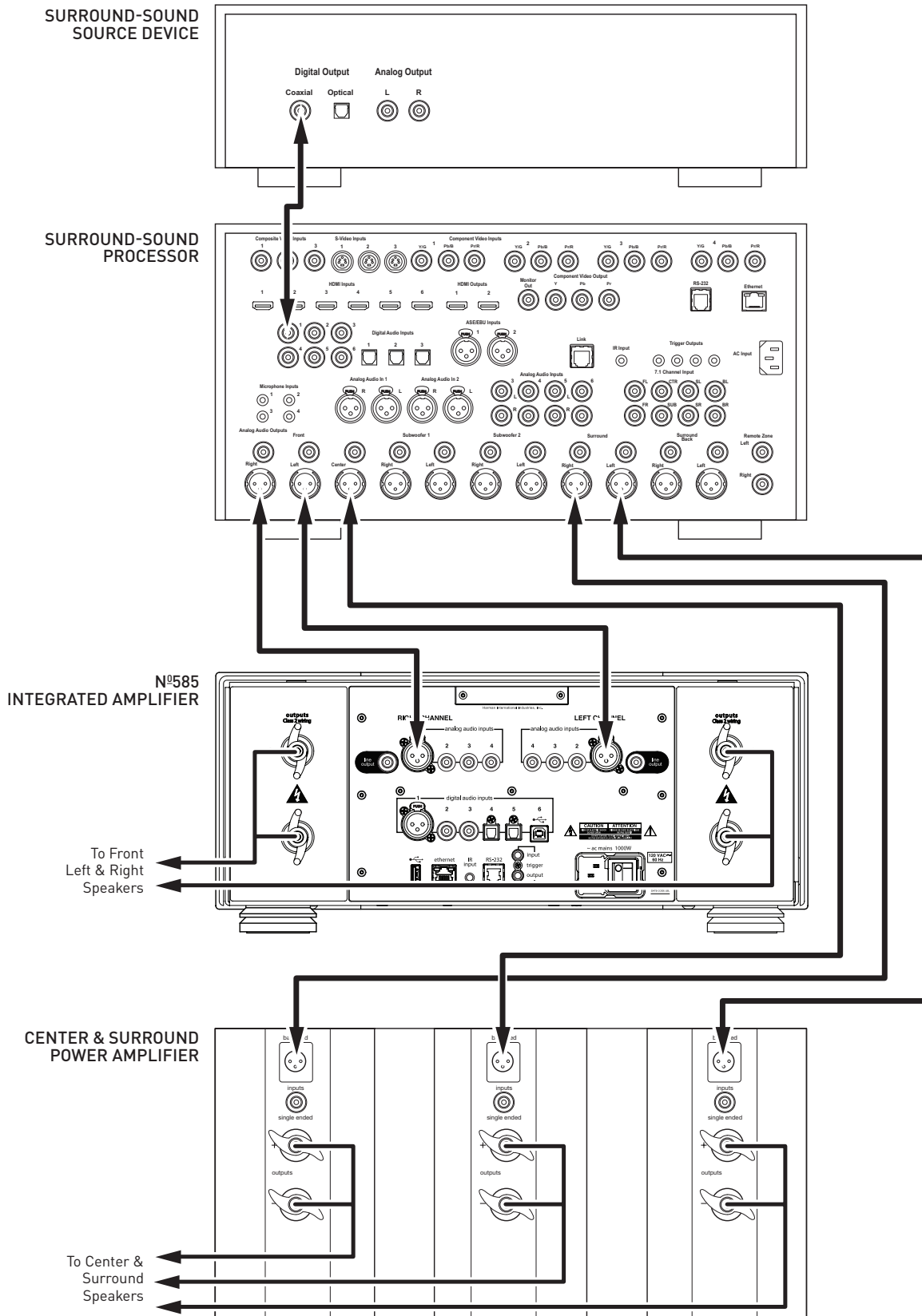

## TROUBLESHOOTING

Incorrect operation is sometimes mistaken for malfunction. If problems occur, see this section for troubleshooting information. If problems persist, contact your authorized Mark Levinson dealer.

### NO POWER

Examine the power cord to ensure that it is connected to both the AC mains connector and a working, *unswitched* electrical outlet.

Make sure the N°585 is powered on with the rear-panel Power switch.

Examine the electrical circuit breaker to ensure that power is being supplied to the electrical outlet to which the N°585 is connected.

Make sure the N°585 is *not* in standby. The front-panel standby LED illuminates fully and continually when the N°585 is On. The LED flashes slowly when the N°585 is in Standby mode.

### REMOTE CONTROL DOES NOT OPERATE

Eliminate obstructions between the remote control IR transmitter and the IR receiver on the N°585's front-panel display.

Make sure the rear-panel IR input connector is *not* being used.

Make sure the remote control is positioned within 17 feet (5m) of the N°585's front panel. |

Make sure the remote control signal is being received at the IR receiver on the N°585's front-panel display at a reasonable angle.

Make sure the IR receiver on the N°585's front-panel display is not exposed to strong sunlight, halogen light, or fluorescent light. This can cause IR reception to become unreliable.

Replace the remote control batteries.

### NO SIGNAL AT THE SPEAKER OR LINE OUTPUTS

Examine all audio cables to ensure a solid connection between the N°585 and all associated components.

Examine the speaker cables to ensure a solid connection between the N°585 and the speakers.

Make sure that the connected speakers are operational.

Make sure the volume is set to an audible level.

Make sure the mute is deactivated.

Make sure the Offset setting for the selected input is not reducing the volume to an inaudible level.

Make sure all associated components are connected to working electrical outlets and powered on.

Make sure the source device connected to the selected N°585 input is producing an output signal.

### "MISSING" INPUT

Make sure the Name parameter for the selected input has not been set to Unused in the Setup menu.

## AUDIO HAS A HUMMING SOUND

Disconnect components one at a time to isolate the problem.

Once the problem is identified, make sure the problematic component is properly grounded and connected to the same electrical circuit as the N°585.

## VOLUME CAN'T BE SET TO MAXIMUM

You have the option of establishing a maximum volume level in the Setup menu. If this option is set, it can prevent the N°585's maximum volume level of 80.0 from being reached. Refer to *Volume Control / MaxVol* on page 6 for more information.

## FRONT-PANEL DISPLAY NOT WORKING

Verify that the Intensity parameter in the Setup menu is not set to Off.

## NO CONNECTIVITY VIA ETHERNET

Verify that the network cables are properly connected between the router, switch or hub and the N°585.

Verify the age of the router, switch or hub. If the router, switch or hub is more than ten years old, there may be a communication issue with the N°585. Power cycle the N°585 and use a newer router, switch or hub between the network and the N°585.

## IF ALL ELSE FAILS...

Power cycle the N°585 with the rear-panel Power switch or by unplugging the power cord, waiting at least 10 seconds between powering the N°585 off and on.

Restore factory-default settings (See *Advanced: Config / Restore* on page 8).

Contact your authorized Mark Levinson dealer.

Contact Mark Levinson Customer Service at 888-691-4171 or [www.marklevinson.com](http://www.marklevinson.com).

# SPECIFICATIONS

## AMPLIFIER SECTION

Output Power:	200W RMS per channel @ 8 $\Omega$ , 20Hz – 20kHz
Damping Factor:	>400 @ 20Hz, referred to 8 $\Omega$
Frequency Response:	20Hz – 20kHz, $\pm 0.13$ dB; 2Hz – 250kHz, +0.2dB/–3dB
Signal-to-Noise Ratio:	>98dB (20Hz – 20kHz, unweighted); >103dB (20Hz – 20kHz, A-wtd), referred to full output – maximum volume setting
Voltage Gain:	40.7dB (maximum volume setting)
Total Harmonic Distortion:	<0.01% @ 1kHz, 200W, 8 $\Omega$ ; <0.1% @ 20kHz, 200W, 8 $\Omega$

## PREAMPLIFIER SECTION: ANALOG

Input Impedance:	>45k $\Omega$ (RCA & XLR)
Input Overload:	>5.5V RMS (RCA & XLR)

## PREAMPLIFIER SECTION: DIGITAL

Sample Rates/Bit Depth:	PCM: 32kHz, 44.1kHz, 48kHz, 88.2kHz, 96kHz, 176.4kHz, 192kHz/up to 32-bit; DSD: Native, single- and double-speed
-------------------------	---

## GENERAL

Analog Audio Connectors:	3 pairs single-ended inputs (RCA); 1 pair balanced inputs (XLR); 1 pair single-ended line outputs (RCA); 1 pair loudspeaker outputs ("Hurricane" binding posts w/banana sockets that accept spade lugs with 1/4" (6.3mm) spacing up to 1/8" (3mm) thick)
Digital Audio Connectors:	1 balanced AES/EBU input (XLR); 2 coaxial S/PDIF inputs (RCA); 2 optical inputs (Tos-Link); 1 asynchronous USB input (USB-B)
Control Connectors:	1 RS-232 port (RJ-12 connector); 1 IR input (1/8" phone jack); 1 programmable 12V DC trigger output (1/8" phone jack), 100mA maximum; 1 programmable 12 DC trigger input (1/8" phone jack); 1 Ethernet port (RJ-45 connector)
Mains Voltage:	100V AC, 115V AC, or 230V AC (factory-set)
Power Consumption:	Maximum 1000W (power on)
Unit Dimensions (H x W x D):	6.9" (175mm) – without feet; 7.59" (193mm) – with feet x 17.25" (438mm) x 19.95" (507mm)
Packaging Dimensions (H x W x D):	19" (483mm) x 26" (660mm) x 26" (660mm)
Weight:	72 lb (32.6kg) – net; 96 lb (43.4kg) – with packaging

**PHONO STAGE (N<sup>o</sup>585.5 ONLY)**

Riaa Frequency Response:	20Hz to 20kHz, $\pm 0.3$ dB
Infrasonic Filter:	Defeatable, 15Hz, 2nd order (12dB/octave)

**Moving Magnet Mode:**

Input Resistance:	47k $\Omega$
Input Capacitance:	Selectable; 50, 100, 150, 200, or 680pF
Gain:	40dB @ 1kHz
Total Harmonic Distortion Plus Noise:	<0.03%, 20Hz to 20kHz, 2VRMS output
Signal-To-Noise Ratio (Referred To 2Vrms Output):	>97dB (20Hz to 20kHz, wideband, unweighted) >102dB (A-weighted) >110dB @ 20Hz to 20kHz (spot noise)
Maximum Input Level:	>95mV @ 1kHz; >285mV @ 20kHz

**Moving Coil Mode:**

Input Resistance:	Selectable; 20, 33, 50, 66, 100, 200, 330, 500, 1000, or 47k $\Omega$
Input Capacitance:	50pF
Gain:	Selectable; 50, 60, or 70dB @ 1kHz
Total Harmonic Distortion Plus Noise:	50dB gain setting: <0.02%, 20Hz to 20kHz, 2VRMS output 60dB gain setting: <0.02%, 20Hz to 20kHz, 2VRMS output 70dB gain setting: <0.04%, 20Hz to 20kHz, 2VRMS output
Signal-To-Noise Ratio (Referred To 2Vrms Output):	50dB gain setting: >87dB (20Hz to 20kHz, wideband, unweighted) 50dB gain setting: >94dB (A-weighted) 50dB gain setting: >100dB at 20Hz to 20kHz (spot noise) 60dB gain setting: >77dB (20Hz to 20kHz, wideband, unweighted) 60dB gain setting: >84dB (A-weighted) 60dB gain setting: >90dB at 20Hz to 20kHz (spot noise) 70dB gain setting: >68dB (20Hz to 20kHz, wideband, unweighted) 70dB gain setting: >74dB (A-weighted) 70dB gain setting: >80dB at 20Hz to 20kHz (spot noise)
Maximum Input Level:	50dB gain setting: >30mV @ 1kHz; >105mV @ 20kHz 60dB gain setting: >9.5mV @ 1kHz; >90mV @ 20kHz 70dB gain setting: >3.2mV @ 1kHz; >30mV @ 20kHz



HARMAN International Industries, Incorporated  
8500 Balboa Boulevard  
Northridge, CA 91329 USA

© 2017 HARMAN International Industries, Incorporated. All rights reserved.

Mark Levinson is a registered trademark of HARMAN International Industries, Incorporated.

Blu-ray is a trademark of the Blu-ray Disc Association.

SACD (Super Audio CD) is a trademark of Sony Corporation.

Other company and product names may be trademarks of the respective companies with which they are associated.

This document should not be construed as a commitment on the part of HARMAN International Industries, Incorporated. The information it contains, as well as the features, specifications and appearance of the product, is subject to change without notice. HARMAN International Industries, Incorporated, assumes no responsibility for errors that may appear within this document.

For customer service and product shipment information, refer to our Web site: [www.marklevinson.com](http://www.marklevinson.com)

Part No. 070-90060 Rev: A.0

[www.marklevinson.com](http://www.marklevinson.com)