

Nº585

Nº585.5

INTEGRATED AMPLIFIER QUICK START GUIDE

mark
levinson.

TABLE OF CONTENTS

About This Document	1
Installation Considerations Unpacking, Placement and Ventilation, Power Requirements, Operating States	2
Getting Started Front-Panel Overview, Rear-Panel Overview, Remote Control Overview	4
Quick Setup and Listen Remote Control, Initial Connections	11
Troubleshooting	14
Specifications	15

ABOUT THIS DOCUMENT

For the purposes of this guide, we will refer both the N°585.5 and the N°585 as simply the N°585 except when referencing the phono features exclusive to the N°585.5. This quick-start guide contains all the information you will need to unpack your N°585, connect it to the rest of your audio system, turn it on and have a first listen. Before you attempt more extensive use of this sophisticated integrated amplifier, you must read the full *N°585 User Guide*, which is available online at www.marklevinson.com. The User Guide contains information about features, operations, adjustments, alternate connections and networking that will enhance your N°585's operation and performance.

INSTALLATION CONSIDERATIONS

UNPACKING

When unpacking your N°585:

- Save all packing materials in case you need to ship your N°585 in the future.
- Inspect your N°585 for signs of damage during shipment. If you discover damage, contact your authorized Mark Levinson® dealer for assistance in making appropriate claims.
- Locate and remove the accessory box from the shipping carton. Make sure that all of the items listed below are included. If any are missing, contact your authorized Mark Levinson dealer.

1 x IEC power cord (terminated according to the region to which the unit is shipped)

1 x N°585 remote control

2 x AAA alkaline batteries

1 x #1 Phillips screwdriver

1 x Pair white gloves (for use during unpacking and initial setup)

1 x N°585 Quick-Start Guide

NOTE: The N°585 User Guide is available for download online at www.marklevinson.com.

Please register your N°585 within 15 days of your purchase. Register online at www.marklevinson.com. Retain your original, dated sales receipt as proof of warranty coverage.

PLACEMENT AND VENTILATION

- Install the integrated amplifier on a shelf with nothing above it, such as the top shelf in an open rack, to ensure proper ventilation. Do NOT install the integrated amplifier inside of an enclosed cabinet or rack.
- Ensure that you install the integrated amplifier on a solid, flat and level surface.
- Install the integrated amplifier as close as possible to associated audio components to keep interconnecting cables as short as possible.
- Select a dry, well-ventilated location that is out of direct sunlight.
- DO NOT expose the N°585 to high temperatures, humidity, steam, smoke, dampness, or excessive dust.

POWER REQUIREMENTS

The N°585 is configured at the factory for 100, 115, or 230 VAC power operation at 50Hz or 60Hz. Before operating the amplifier, ensure that the power label on the rear panel near the AC input connector indicates the correct operating voltage. A detachable IEC power cable intended for use in the region where the N°585 is sold is included.

Connection to an AC voltage other than that for which the N°585 is intended can create a safety and fire hazard and may damage the unit. If you have any questions about the voltage requirements for your N°585 or about the line voltage in your area, contact your authorized Mark Levinson dealer before plugging the N°585 into an AC power outlet.

WARNING! MAKE SURE all components in the audio system are properly grounded. Do NOT defeat the safety purpose of polarized or grounding-type plugs with “ground-lifter” or “cheater” adapters. Doing so may cause dangerous voltage to build up between components, which may result in personal injuries and/or product damage.

NOTE: The N°585 is capable of passing remarkable sound at exceptional power levels. Depending on your listening habits, the demands of your loudspeakers and the number of power amplifiers present in your system, it is possible that your electrical service may become the limiting performance factor in your system.

If this case occurs, consider installing a dedicated AC circuit for the system. If more than one AC circuit is providing power to your system, contact a licensed electrician to ensure that all components are operating with the same solid, low-impedance ground reference.

You should unplug the N°585 from the AC wall outlet during lightning storms and extended periods of non-use.

CAUTION: BEFORE moving the N°585, make sure it is powered off by removing the power cord from the AC power outlet and the unit’s rear panel.

OPERATING STATES

The N°585 has three operating states:

Off: The AC mains power is disconnected by using the N°585’s rear-panel Power switch or by removing the power cord from the rear panel.

Standby: The N°585 Standby mode has three settings that can be selected via the Setup menu: Green, Power Save, and Normal.

Green: This mode removes power from almost all of the N°585’s circuits, allowing the unit to be activated only via an IR control signal, a 5V – 12V trigger or a press of the Standby button. This mode provides maximum power conservation and is the factory-default Standby mode.

Power Save: This mode removes power from the N°585’s audio circuits, but keeps the control circuitry powered and ready to receive commands from either the front panel controls or the remote control. This mode provides moderate power conservation.

Normal: This mode shuts off the N°585’s display and mutes its audio outputs, but keeps all of its control and audio circuits powered. This mode provides the least amount of power conservation but allows the N°585’s audio circuits to remain warmed up to deliver optimal performance at all times.

On: The entire N°585 is powered up and all configured outputs are active.

The N°585 has an Auto Off feature that automatically places it into the Standby mode after 20 minutes of no user control input or audio signal passing through the unit. The factory-default setting for the Auto Off feature is on (engaged). You can turn the Auto Off feature off (disengaged) in the Setup menu.

GETTING STARTED

FRONT-PANEL OVERVIEW

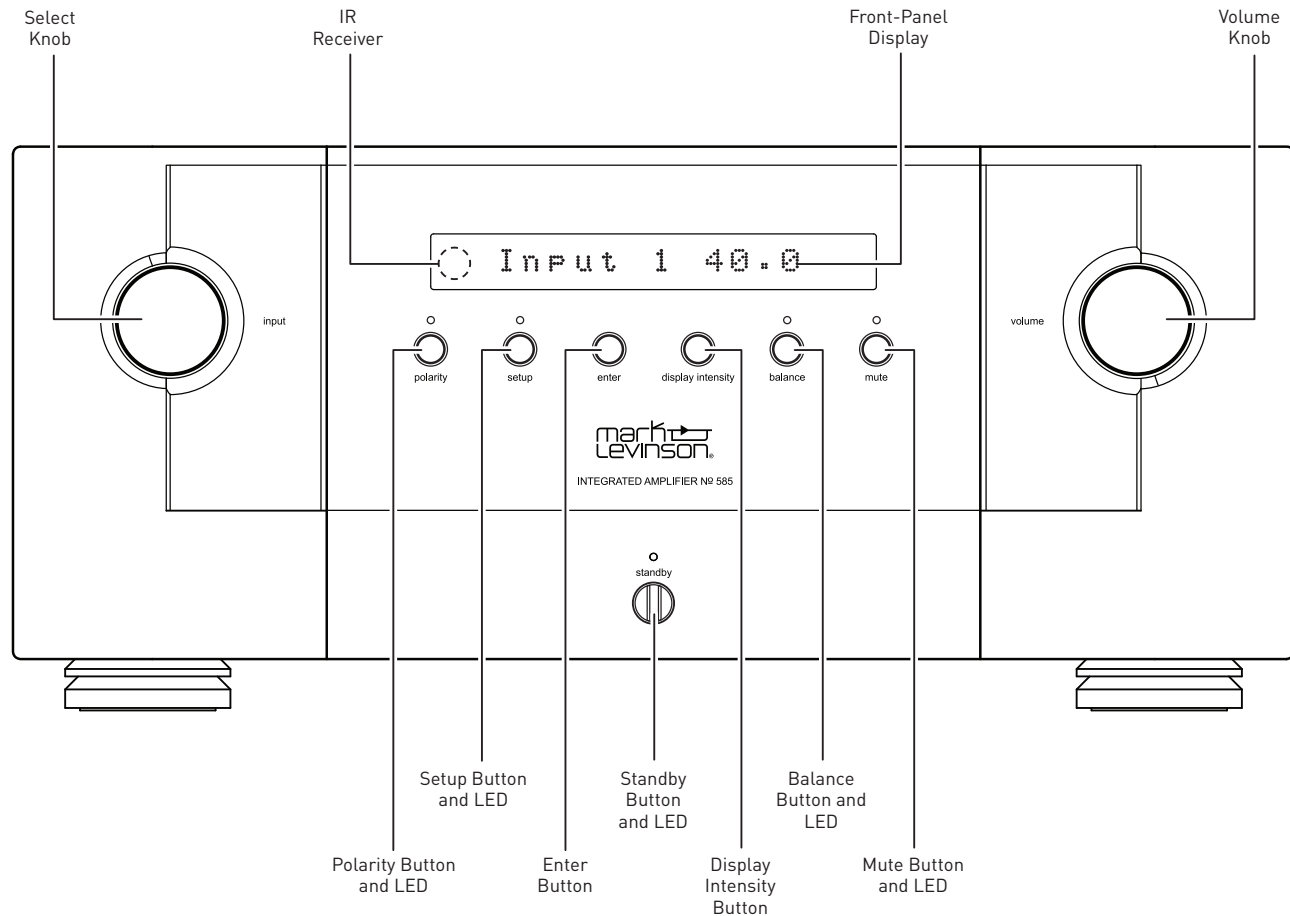

Front-panel controls/indicators

NOTE: For complete information about the functions of the front-panel controls and their settings parameters, see the *N°585 User Guide*, at www.marklevinson.com.

Select knob: Rotate this knob to select the desired input to send to the Speaker outputs and Line outputs. The name and volume level of the selected input are indicated on the Front-Panel display. (Note: The Select knob will bypass any input for which the Input Name Setup menu parameter has been set to “Unused.”)

IR receiver: The IR receiver receives commands from the included remote control when the N°585 is not being

controlled via its rear-panel IR Input connector (see *Rear-Panel Overview*, page 7, for more information).

Polarity button and LED: Pressing this button inverts the absolute polarity of the signal. The LED illuminates when the signal’s polarity is inverted.

Setup button and LED: Press this button to display the Setup menu, which you can use to customize the N°585 to suit your other system components, individual preferences and listening space. The Setup LED lights when the Setup menu is active.

Enter button: Press this button to select or deselect a menu item when the Setup menu is displayed. The Enter button does not function during normal operation.

Display Intensity button: Press this button to change the intensity of the N°585's front-panel Display characters and its front-panel LEDs. Multiple presses of the Display Intensity button cycle through the available brightness levels: High, Medium, Low, and Off.

Balance button and LED: Press this button to set the left-to-right channel balance of the Speaker outputs (and the Line outputs, if you have set them to Variable in the Setup menu). The Balance LED lights when the balance function is active.

NOTE: When the balance function is inactive, the Balance LED remains lit if the left-to-right channel balance of the Main output connectors is offset.

Mute button and LED: Press this button to mute and unmute the level of the speaker outputs (and the Line outputs, if you have set them to Variable in the Setup menu) by the amount determined in the Setup menu. The LED lights when the mute function is active.

Front-Panel display: This 16-character alphanumeric display provides information about the N°585's operating status. During normal operation it indicates the name and volume level of the selected input.

Volume knob: Turn this knob to adjust the volume level of the Speaker outputs (and of the Line outputs if you have set them to Variable in the Setup menu). The minimum volume level is OFF; the maximum volume level is determined in the Setup menu.

Whenever you select an input the N°585 applies the volume offset selected for it in the Setup menu to the Speaker output volume level (and to the Line output volume level, if you have set the Line outputs to Variable in the Setup menu).

Standby button and LED: Press this button to put the N°585 into and out of the Standby mode. The LED illuminates when the N°585 is On. When the N°585 is in either the Green, Normal or Power Save Standby mode it flashes slowly.

REAR-PANEL OVERVIEW

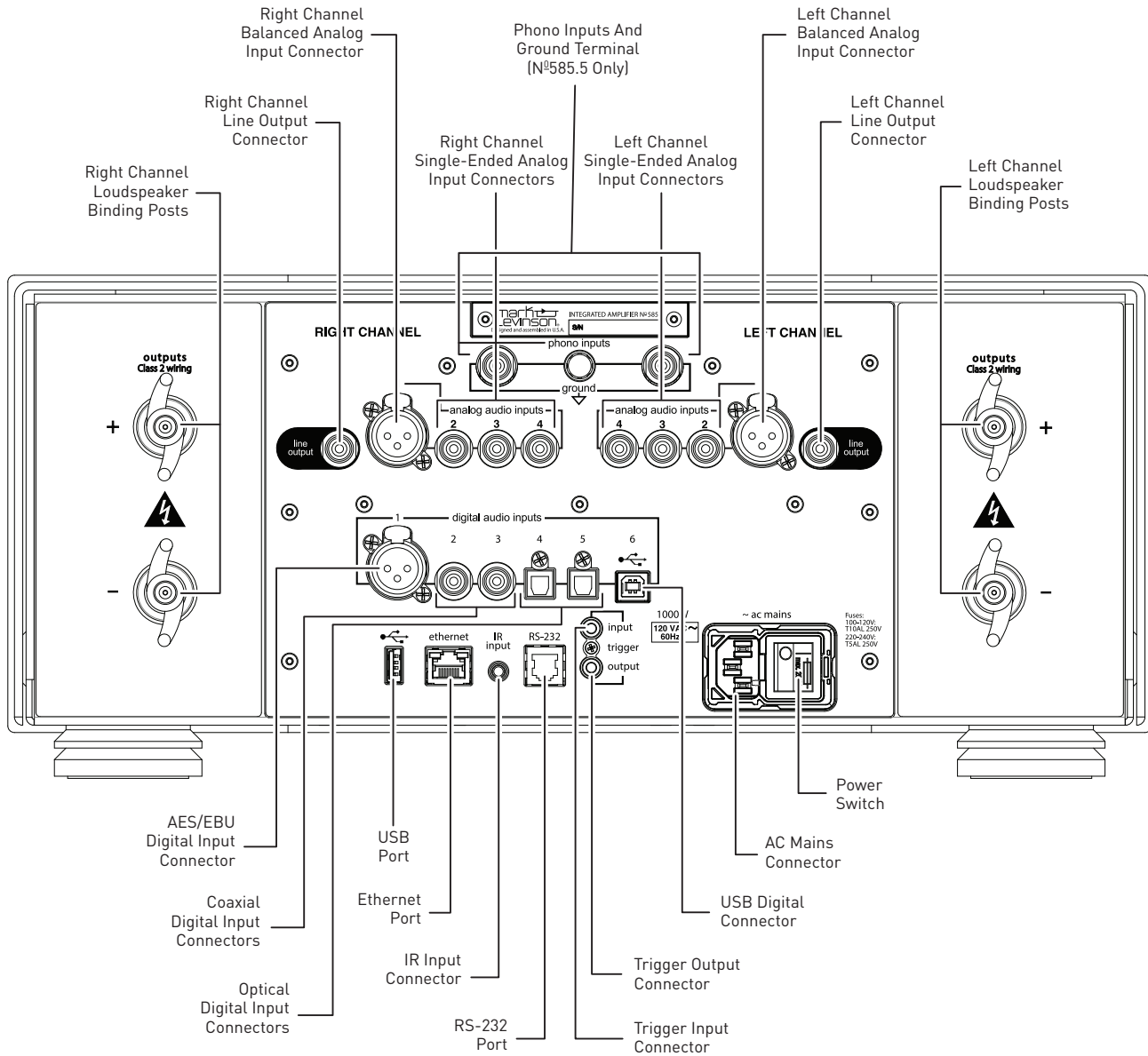

NOTE: For complete information about the rear-panel connections, see the *N°585 User Guide*, at www.marklevinson.com.

Left and right channel loudspeaker binding posts: The N°585 utilizes custom-made, gold-plated, high-current loudspeaker binding posts. The positive binding posts, labeled + (positive), are red; the negative binding posts are black and are labeled – (negative).

The binding posts can accommodate speaker cables terminated in untinned bare wire, spade lugs and banana plugs.

CAUTION: DO NOT OVERTIGHTEN the binding posts. The innovative design of these binding posts provides more leverage; hence, high-contact, tight pressure connections are achieved when finger-tightened. **DO NOT FORCE** the binding post “wings” over a bent or oversized connector. Doing so may damage the binding post.

NOTE: The audio outputs of this power amplifier are considered Class 2 (CL2) circuits in North America. This means the wire connected between this amplifier and the speaker(s) shall be rated at minimum Class 2 (CL2) and shall be installed according to the U.S. National Electrical Code (NEC) Article 725 or Canadian Electrical Code (CEC) Section 16.

Line output connectors: These RCA connectors provide a line-level left-channel and right-channel signal that can be used to send the selected input to a powered subwoofer, to a second listening zone or to recording components such as CD recorders or tape decks.

The Line outputs are configured in the Setup menu as *Fixed* (for use with recording components or a second audio zone). When configured as *Fixed*, the Line outputs are not affected by any of the N°585's front-panel controls except for the Polarity button.

If your system includes a powered subwoofer you can configure the Line Outputs in the Setup menu as *Variable*. When so configured, the Line Outputs will follow the settings of the Volume, Balance and Mute controls.

Balanced analog input connectors: These connectors accept left-channel and right-channel balanced input signals from source components with balanced (male XLR) output connectors.

Balanced connector pin assignments:

- Pin 1: Signal ground
- Pin 2: Signal + (non-inverting)
- Pin 3: Signal – (inverting)
- Connector ground lug: Chassis ground

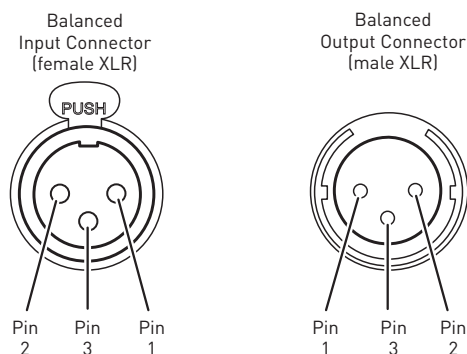

Single-ended input connectors: These connectors accept left-channel and right-channel single-ended input signals from source components without balanced output connectors.

Digital input connectors: The N°585 has six digital audio input connectors: An AES/EBU-format XLR connection (numbered 1), two coaxial (RCA) S/PDIF connections (numbered 2 and 3), two optical (TOSLINK) S/PDIF connections (numbered 4 and 5) and a USB-B digital audio connection (numbered 6).

USB port: This USB Type-A connector allows you to perform firmware upgrades that may be offered in the future. Check our Web site (www.marklevinson.com) for available updates; if one is offered, follow the instructions on the Web site. The USB port also allows you to import and export setup configuration information via a USB memory stick, and provides a means to update the N°585's firmware. See the *N°585 User Guide* for more information.

Ethernet port: This port supports connection to a home network. For information on how to configure and use the Ethernet port, see the *N°585 User Guide*.

IR input connector: This connector accepts IR (infrared) control signals from other equipment.

RS-232 port: This RJ-11 connector provides serial control through a standard RS-232 connection.

Trigger output connector: This 3.5mm tip/sleeve connector can be used to activate other components in the audio system and listening room, such as amplifiers, lights and window shades. A 12V 100mA DC signal is output whenever the N°585 is on. (See illustration below.)



Trigger input connector: This 3.5mm tip/sleeve connector can be connected to the trigger output of another system component or control system that supplies a trigger voltage. Whenever the N°585 detects a voltage between 5V and 12V DC at this connection it will turn On; when the trigger signal at this connection ceases the N°585 will enter the Standby mode. (See illustration above.)

AC Mains connector: This connector provides AC power to the N°585 when the supplied power cord is connected from it to an AC electrical outlet.

You should unplug the N°585 from the AC wall outlet during lightning storms and extended periods of non-use.

Power switch: this mechanical switch turns the N°585's power supply on or off. During normal operation, do not use the Power switch to power off the N°585. Instead, use the Standby button to place the N°585 into Standby.

REMOTE CONTROL OVERVIEW

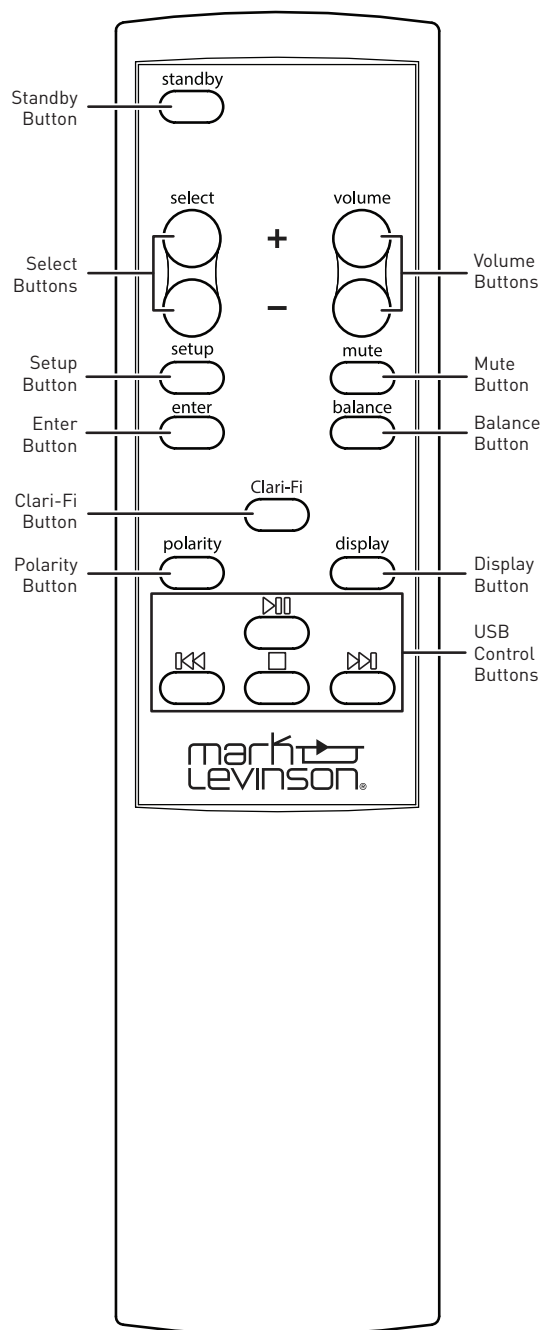

NOTE: For complete information about the remote control functions, see the *N°585 User Guide*, at www.marklevinson.com.

Standby button: Press this button to put the N°585 into and out of the Standby mode.

Select buttons: Press these buttons to select the desired input. The name and volume level of the selected input are indicated on the front-panel display.

Volume +/- buttons: Press these buttons to adjust the volume level of the Speaker outputs (and of the Line outputs if you have set them to *Variable* in the Setup menu). The minimum volume level is OFF; the maximum volume level is determined in the Setup menu.

Whenever you select an input, the N°585 applies the volume offset selected for it in the Setup menu to the Main output volume level (and to the Line output volume level if you have set it to *Variable* in the Setup menu).

Setup button: Press this button to display the Setup menu, which you can use to customize the N°585 to suit your individual preferences, listening space and other system components. The Setup LED on the front panel illuminates when the Setup menu is active.

Mute button: Press this button to mute and unmute the level of the speaker outputs (and the Line outputs, if you have set them to *Variable* in the Setup menu) by the amount determined in the Setup menu. The Mute LED on the front panel lights when the mute function is active.

Enter button: Press this button to select or deselect a menu item when the Setup menu is displayed.

Balance buttons: Press this button to set the left-to-right channel balance. The Balance LED illuminates when the balance function is active. (It also remains illuminated when the balance function is inactive if the left-to-right channel balance is offset.)

Clari-Fi button: Pressing this button activates the Clari-Fi circuitry. Clari-Fi analyzes compressed digital audio files during playback and “rebuilds” much of what was lost in compression. (Clari-Fi functions only when a digital input is the active input.)

CLARI·FI™
Music Restoration Technology

GETTING STARTED

Polarity button: Pressing this button inverts the absolute polarity of the signal at the Speaker outputs and the Line outputs. The *Polarity* LED on the front panel illuminates when the signal's polarity is inverted.

Display button: Press this button to change the intensity of the N°585's front-panel display characters and its front-panel LEDs. Multiple presses of the Display button cycle through the available brightness levels: High, Medium, Low, and Off.

USB control buttons: When USB-B (Input 11) is the active input, these buttons control playback of the USB source component.

QUICK SETUP AND LISTEN

REMOTE CONTROL

Battery Installation

Your N°585 remote control comes with two AAA alkaline batteries. To install the batteries, remove the remote control's battery cover, insert the batteries and replace the battery cover. Be sure to observe proper battery polarity.

Using the Remote Control

When using the remote control, aim it toward the N°585's front panel IR receiver. Make sure that no objects, such as furniture, block the remote's view of the receiver. Bright lights, fluorescent lights, and plasma video displays may interfere with the function of the remote.

- The remote has a range of about 17 feet (5m), depending on the lighting conditions.
- You can use the remote at an angle of up to 45° to either side of the N°585.
- Placing the N°585 behind tinted glass will reduce the remote control's effective range.

If the remote control seems to operate intermittently, replace both batteries with new ones.

INITIAL CONNECTIONS

NOTE: For complete information about making connections, see the *N°585 User Guide* at www.marklevinson.com.

CAUTION: Before making connections, make sure the N°585 and all associated components are powered off and disconnected from electrical outlets.

1. Connect your speakers to the N°585's loudspeaker binding posts. Connect the speaker's positive (+) terminal to the N°585's positive (+) red binding post, and the speaker's negative (-) terminal to the N°585's negative (-) black binding post.

CAUTION: Be careful to not short the positive and negative outputs together. Do not short the positive or negative outputs to chassis or any other safety ground.

2. If your system includes a powered subwoofer, connect it to the N°585's Line outputs. (Configure the Line outputs as *Variable* in the Setup menu. See the *N°585 User Guide* for details.)

3. Connect up to four line-level analog source components to the N°585's analog audio inputs. One set of balanced (XLR) connectors and three sets of single-ended (RCA) connectors are available.

4. Connect up to six digital source components to the N°585's digital audio inputs. One AES/EBU (XLR) connector, two coaxial S/PDIF (RCA) connectors, two optical S/PDIF (TOSLINK) connectors and one USB-B connector are available.

5. Connect the supplied power cable to the N°585's AC Mains connector and into an electrical outlet. Power on the N°585 and all associated components.

6. Press the Standby button on the N°585's front panel or remote control to turn it on.

7. Rotate the N°585 select knob or press the Select +/- buttons on the remote to select the N°585 input that corresponds to an input connector to which you connected a source component.

8. Make sure the N°585's volume is set to a reasonable level. Then, begin playing the selected source device.

9. (N°585.5 only) Connect your turn table to the one set of RCA connectors. Connect the turn table ground to the ground terminal on your N°585.5.

NOTE: After connecting all source components to the N°585, we suggest using the Setup menu to set the names of all inputs that have no connected source components to "Unused." This will remove the unconnected inputs from the list of available inputs and they will be skipped when selecting the active input. See the *N°585 User Guide* for details.

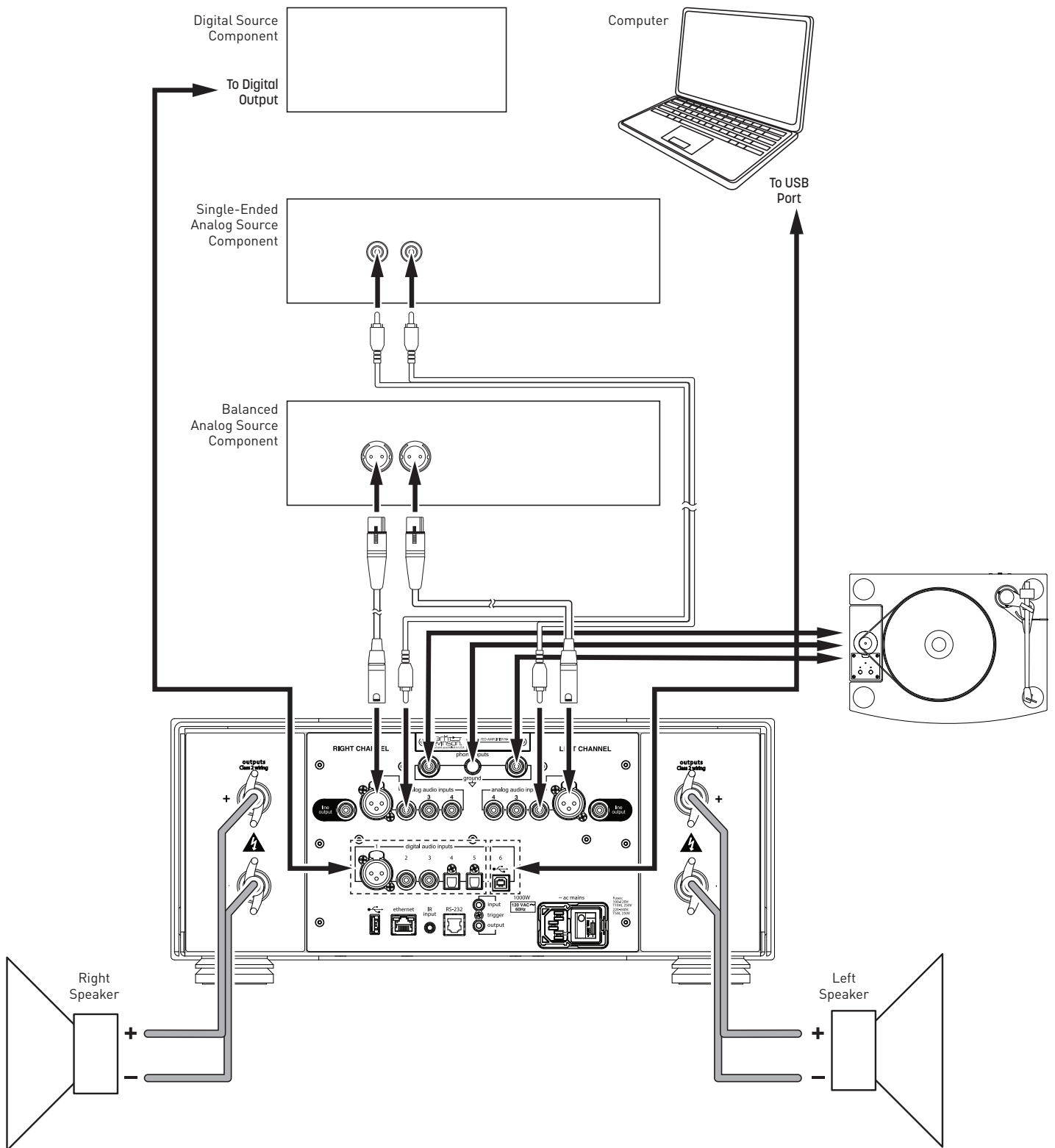

TROUBLESHOOTING

If the N°585 experiences a potentially damaging condition, its built-in protection circuitry will shut off the amplifier and its Front-Panel Display will show one of the error messages listed below. Follow the instructions in the *Solution* column to correct the condition before attempting to use the N°585 again.

ERROR MESSAGE	PROBLEM	SOLUTION
WARNING: DC DETECTED ON [LEFT/RIGHT] CHANNEL	<ul style="list-style-type: none"> The indicated amplifier channel has detected DC on the output which can damage speakers. 	<ul style="list-style-type: none"> Set the rear-panel Power switch to off. Wait 10 seconds and turn the switch back on. If the error message does not clear call your Mark Levinson dealer or Mark Levinson customer service.
WARNING: OVER TEMP [LEFT/RIGHT]	<ul style="list-style-type: none"> Indicated amplifier channel has exceeded thermal limits. 	<ul style="list-style-type: none"> Put the N°585 into standby by pressing the Standby button. Wait 10 to 15 minutes to let the unit cool down and press the Standby button again. If the error message does not clear call your Mark Levinson dealer or Mark Levinson customer service.
WARNING: OVER CURRENT ON [LEFT/RIGHT] CHANNEL	<ul style="list-style-type: none"> Indicated amplifier channel has exceeded current limits. 	<ul style="list-style-type: none"> Set the rear-panel Power switch to off. Wait 10 seconds and turn the switch back on. If the error message does not clear set the Power switch to off and disconnect the channel's speaker wire from the N°585. Wait 10 seconds and turn the Power switch back on. If the error message does not clear call your Mark Levinson dealer or Mark Levinson customer service.

SPECIFICATIONS

AMPLIFIER SECTION

Output Power:	200W RMS per channel @ 8 Ω , 20Hz – 20kHz
Damping Factor:	>400 @ 20Hz, referred to 8 Ω
Frequency Response:	20Hz – 20kHz, ± 0.13 dB; 2Hz – 250kHz, +0.2dB/-3dB
Signal-to-Noise Ratio:	>98dB (20Hz – 20kHz, unweighted); >103dB (20Hz – 20kHz, A-wtd), referred to full output – maximum volume setting
Voltage Gain:	40.7dB (maximum volume setting)
Total Harmonic Distortion:	<0.01% @ 1kHz, 200W, 8 Ω ; <0.1% @ 20kHz, 200W, 8 Ω

PREAMPLIFIER SECTION: ANALOG

Input Impedance:	>45k Ω (RCA & XLR)
Input Overload:	>5.5V RMS (RCA & XLR)

PREAMPLIFIER SECTION: DIGITAL

Sample Rates/Bit Depth (PCM):	32kHz, 44.1kHz, 48kHz, 88.2kHz, 96kHz, 176.4kHz, 192kHz/up to 32-bit
-------------------------------	--

GENERAL

Analog Audio Connectors:	3 pairs single-ended inputs (RCA); 1 pair balanced inputs (XLR); 1 pair single-ended line outputs (RCA); 1 pair loudspeaker outputs ("Hurricane" binding posts w/banana sockets that accept spade lugs with 1/4" (6.3mm) spacing up to 1/8" (3mm) thick)
Digital Audio Connectors:	1 balanced AES/EBU input (XLR); 2 coaxial S/PDIF inputs (RCA); 2 optical inputs (Tos-Link); 1 asynchronous USB input (USB-B)
Control Connectors:	1 RS-232 port (RJ-12 connector); 1 IR input (1/8" phone jack); 1 programmable 12V DC trigger output (1/8" phone jack), 100mA maximum; 1 programmable 12 DC trigger input (1/8" phone jack); 1 Ethernet port (RJ-45 connector)
Mains Voltage:	100V AC, 115V AC, or 230V AC (factory-set)
Power Consumption:	Maximum 1000W (power on)
Unit Dimensions (H x W x D):	6.9" (175mm) – without feet; 7.59" (193mm) – with feet x 17.25" (438mm) x 19.95" (507mm)
Packaging Dimensions (H x W x D):	19" (483mm) x 26" (660mm) x 26" (660mm)
Weight:	72 lb (32.6kg) – net; 96 lb (43.4kg) – with packaging

PHONO STAGE (N^o585.5 ONLY)

Riaa Frequency Response: 20Hz to 20kHz, ± 0.3 dB

Infrasonic Filter: Defeatable, 15Hz, 2nd order (12dB/octave)

Moving Magnet Mode:

Input Resistance: 47k Ω

Input Capacitance: Selectable; 50, 100, 150, 200, or 680pF

Gain: 40dB @ 1kHz

Total Harmonic Distortion Plus Noise: <0.03%, 20Hz to 20kHz, 2VRMS output

Signal-To-Noise Ratio (Referred To 2Vrms Output): >97dB (20Hz to 20kHz, wideband, unweighted)
>102dB (A-weighted)
>110dB @ 20Hz to 20kHz (spot noise)

Maximum Input Level: >95mV @ 1kHz; >285mV @ 20kHz

Moving Coil Mode:

Input Resistance: Selectable; 20, 33, 50, 66, 100, 200, 330, 500, 1000, or 47k Ω

Input Capacitance: 50pF

Gain: Selectable; 50, 60, or 70dB @ 1kHz

Total Harmonic Distortion Plus Noise: 50dB gain setting: <0.02%, 20Hz to 20kHz, 2VRMS output
60dB gain setting: <0.02%, 20Hz to 20kHz, 2VRMS output
70dB gain setting: <0.04%, 20Hz to 20kHz, 2VRMS output

Signal-To-Noise Ratio (Referred To 2Vrms Output): 50dB gain setting: >87dB (20Hz to 20kHz, wideband, unweighted) 50dB gain setting: >94dB (A-weighted)
50dB gain setting: >100dB at 20Hz to 20kHz (spot noise)
60dB gain setting: >77dB (20Hz to 20kHz, wideband, unweighted) 60dB gain setting: >84dB (A-weighted)
60dB gain setting: >90dB at 20Hz to 20kHz (spot noise)
70dB gain setting: >68dB (20Hz to 20kHz, wideband, unweighted) 70dB gain setting: >74dB (A-weighted)
70dB gain setting: >80dB at 20Hz to 20kHz (spot noise)

Maximum Input Level: 50dB gain setting: >30mV @ 1kHz; >105mV @ 20kHz
60dB gain setting: >9.5mV @ 1kHz; >90mV @ 20kHz
70dB gain setting: >3.2mV @ 1kHz; >30mV @ 20kHz



HARMAN International Industries, Incorporated
8500 Balboa Boulevard
Northridge, CA 91329 USA

© 2017 HARMAN International Industries, Incorporated. All rights reserved.

Mark Levinson is a registered trademark of HARMAN International Industries, Incorporated.

Other company and product names may be trademarks of the respective companies with which they are associated.

This document should not be construed as a commitment on the part of HARMAN International Industries, Incorporated. The information it contains, as well as the features, specifications and appearance of the product, is subject to change without notice. HARMAN International Industries, Incorporated, assumes no responsibility for errors that may appear within this document

For customer service and product shipment information, refer to our Web site: www.marklevinson.com

Part No. 070-90061 Rev: A

www.marklevinson.com