

Operating Manual

Mark Levinson®
N° 33
Reference Monaural
Power Amplifier

Madrigal Audio Laboratories, Inc.

WARNING: TO REDUCE THE RISK OF FIRE OR ELECTRIC SHOCK, DO NOT EXPOSE THIS APPLIANCE TO RAIN OR MOISTURE.

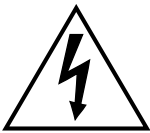
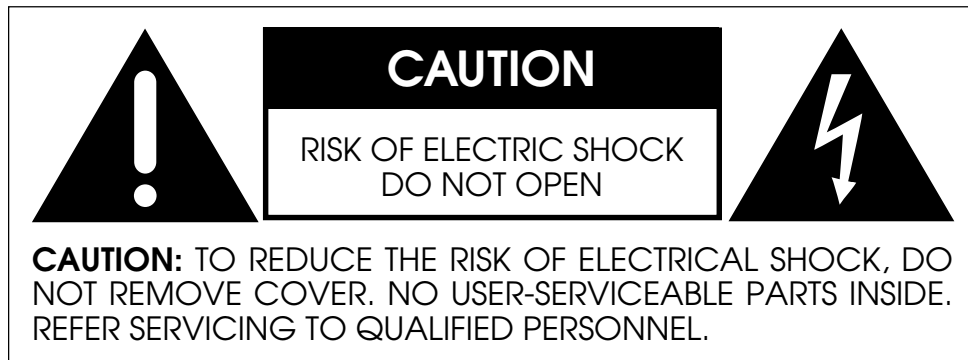

The lightning flash with arrowhead symbol, within an equilateral triangle, is intended to alert the user to the presence of uninsulated “dangerous voltage” within the product’s enclosure that may be of sufficient magnitude to constitute a risk of electric shock to persons.



The exclamation point within an equilateral triangle is intended to alert the user to the presence of important operating and maintenance (servicing) instructions in the literature accompanying the appliance.



Marking by the “CE” symbol (shown left) indicates compliance of this device with the EMC (Electromagnetic Compatibility) and LVD (Low Voltage Directive) standards of the European Community.

The information contained in the manual is subject to change without notice. The most current version of this manual will be posted on our web site at <http://www.madrigal.com>.

Important Safety Instructions

Please read all instructions and precautions carefully and completely before operating your Mark Levinson® power amplifier.

1. **ALWAYS** disconnect your entire system from the AC mains before connecting or disconnecting any cables, or when cleaning any component.
2. This product must be terminated with a three-conductor AC mains power cord which includes an earth ground connection. To prevent shock hazard, all three connections must **ALWAYS** be used.
3. AC extension cords are **not** recommended for use with this product.
4. **NEVER** use flammable or combustible chemicals for cleaning audio components.
5. **NEVER** operate this product with any covers removed.
6. **NEVER** wet the inside of this product with any liquid.
7. **NEVER** pour or spill liquids directly onto this unit.
8. **NEVER** block air flow through ventilation slots or heatsinks.
9. **NEVER** bypass any fuse.
10. **NEVER** replace any fuse with a value or type other than those specified.
11. **NEVER** attempt to repair this product. If a problem occurs, contact your Mark Levinson® retailer.
12. **NEVER** expose this product to extremely high or low temperatures.
13. **NEVER** operate this product in an explosive atmosphere.
14. **ALWAYS** keep electrical equipment out of the reach of children.
15. **ALWAYS** unplug sensitive electronic equipment during lightning storms.

From all of us at Madrigal Audio Laboratories, thank you for choosing the Mark Levinson Nº 33 Reference Monaural Power Amplifier.

A great deal of effort went into the design and construction of this precision device. Used properly, it will give you many years of enjoyment.

Table of Contents

| | |
|---|-----------|
| Unpacking the N°33 | 6 |
| Handling the Shipping Crate | 6 |
| Unpacking Procedure | 6 |
| Placement Considerations | 9 |
| Ventilation | 9 |
| Spiking the Amplifier | 10 |
| Operating Voltage | 11 |
| <i>N°33 AC mains current requirements</i> | <i>12</i> |
| <i>N°33 rear-panel label</i> | <i>12</i> |
| Special Design Features | 13 |
| Massive Power Supply | 13 |
| AC Regeneration | 13 |
| Fully balanced design | 14 |
| True Voltage Source | 14 |
| Extensive Protection | 15 |
| Front Panel | 16 |
| Rear Panel | 17 |
| <i>Remote turn-on tip polarity</i> | <i>20</i> |
| Care & Maintenance | 23 |
| U.S. and Canadian Warranty | 24 |
| 90-Day Limited Warranty | 24 |
| Five Year Extended Warranty | 24 |
| Obtaining Service | 25 |
| Specifications | 26 |
| Dimensions: N°33 | 27 |

Unpacking the N°33

Handling the Shipping Crate

The shipping weight of each of your N°33 Reference Monaural Power Amplifiers is approximately 435 pounds (198 kg). Any freight this massive must be handled with extreme care to avoid injury. At least two strong people are required (more is nice) to unpack the N°33 amplifiers safely once they have been delivered to the appropriate location in their shipping crates.

Included with your new Mark Levinson amplifier is two pairs of knit, white gloves designed to assist you in the initial unpacking and placement of your new purchase. Please accept them as a token of our appreciation for having purchased one of our products.



Warning!

Under no circumstances should you consider unpacking your amplifier without adequate assistance, as both personal injury and damage to the product is likely unless you follow the procedures listed below.

The shipping crates used for transporting the N°33 power amplifiers should be kept upright (as indicated by the arrows on the outside of the crates) at all times during the unpacking procedure.

Save all packing material for future use. In the event that you need to ship your N°33 amplifiers, *only* their original, purpose-designed shipping crates are acceptable. Any other method of shipping these heavy products will almost certainly result in damage to the amplifiers.

Unpacking Procedure

The shipping crates for your amplifiers are modular in design to facilitate the packing and unpacking of these massive products. Nonetheless, there is no escaping the fact that these amplifiers are heavy.



Caution!

Do not attempt to lift the N°33 from its packing crate alone. Never attempt to lift a N°33 power amplifier while bending from the waist. Always stand as straight as possible and use your leg muscles to lift the amplifier. Never attempt to lift the entire amplifier at one time (even with two people). Instead, always lift either one end or the other, leaving the remaining end to be supported by the base of the shipping crate or the floor.

To safely unpack the N°33 amplifier:

1 CAREFULLY CUT THE NYLON STRAPPING AROUND THE CRATE

These straps may be under some tension, and the ends may snap outward when that tension is first released. Stand to one side when cutting each nylon strap to avoid any chance of the strap contacting you.

2 REMOVE ALL CLAMPS AND THE FOUR SCREWS HOLDING THE TOP OF THE CRATE TO THE FOUR SIDES

You may use a large screwdriver or a small crowbar to pry the clamps off the crate. Set these clamps aside. (Save all shipping materials for possible future use.)

Two screws are located at each end of the short side of the top of the crate. Remove and save these four screws, which secure the top of the crate to the sides. (Save all shipping materials for possible future use.)

3 LIFT OFF THE TOP OF THE CRATE, AND SET IT ASIDE

The various pieces of the crate are designed to fit snugly into one another. Do not be surprised if removing the top requires some effort, especially if unpacking takes place in a humid climate where the wood may have swelled slightly from the moisture.

4 LIFT ALL FOUR SIDES UP AND AWAY FROM THE BASE

The sides and ends may be lifted up and out of their respective slots in the base of the crate, and set to aside. As with the top, this may require some effort. You should now have the N°33 standing on the wooden base of the crate, inside its plastic shipping bag.

5 USING A RATCHETED SOCKET WRENCH, REMOVE THE FOUR BOLTS HOLDING THE N°33 TO THE BASE OF THE CRATE

The N°33 is attached to the base of its shipping crate with four bolts, accessible between the pieces of blue, dense foam along the sides of the base. These bolts attach directly to the bottom of the feet of the N°33 from underneath, and have $\frac{1}{16}$ " hexagonal heads. Using a ratcheted socket wrench, remove these four bolts *from underneath* each amplifier.

6 REMOVE THE WOODEN RETAINING BAR FROM THE FRONT OF THE BASE

Two more bolts with $\frac{1}{16}$ " hexagonal heads hold this retainer in place. Remove the bolts and the retaining bar and set them aside.

7 WITH AT LEAST TWO STRONG PEOPLE, CAREFULLY SLIDE THE N°33 FORWARD, OFF THE CRATE'S BASE AND ONTO THE FLOOR

Understand this step completely before attempting it. The N°33 is extremely heavy and must be handled with great care to avoid possible personal injury or damage to the unit when attempting to lift it.

Your Mark Levinson® N°33 power amplifiers incorporate heavy duty casters to facilitate their movement. If your flooring is even slightly fragile, be advised that significant pressure is generated by the N°33's approximately 350 pounds (160 kg) being supported by four round casters. Before you remove the N°33 from its shipping crate's base, you may want to take measures to protect delicate flooring from possible damage.

With two people at the front of the amplifier to support its weight, carefully slide the amplifier forward. (A third person may be needed to hold the crate bottom in place as the amplifier is slid forward.) As the front casters clear the front edge of the crate, the two people in front must begin to support the weight of the front half of the amplifier. There is a "handle" built into the sculpted faceplate for this purpose, just above the Mark Levinson logo. Alternatively, you may also grip the front heatsinks. While supporting the front of the amplifier, continue sliding the amplifier forward until the center section of the amplifier has cleared the edge of the crate's base. The front of the amplifier may then be lowered gently to the floor.

With the amplifier supported by the floor in the front and the crate in the rear, both people should move to the rear of the amplifier. Gripping the rear heatsinks, lift the rear end of the amplifier and slide the base of the crate away. (A third person is helpful in this, if available.) Gently lower the rear of the amplifier to the floor, allowing it to come to rest on its casters.

Congratulations. The hard part is over.

After unpacking your N°33 power amplifiers, **keep all packing materials for future transport**. Shipment of the amplifier without the original packing material will almost certainly result in damage to the amplifier, and is *not* recommended.

Locate and remove all accessory items from the accessory cartons. Accessories for each amplifier include:

4 machined aluminum spiked "feet"

Carefully inspect your amplifier for possible damage. If you discover any, see your Mark Levinson dealer immediately.



Important:

When it comes to high current AC wiring such as the N°33 will typically use, building regulations and electrical codes vary from region to region (sometimes even from one municipality to the next). For this reason, it is impossible for us to anticipate the requirements of your area with regard to high current AC hookups. Please review this manual's section on Operating Voltage and contact a local electrical contractor for advice on connecting your N°33 to the AC mains power in your area.

Placement Considerations

PRECAUTION

For your protection, review “Important Safety Instructions” and “Operating Voltage” before you install your N°33.

Your Mark Levinson N°33 power amplifiers are specifically designed to stand on the floor, and must be used as freestanding units. In most installations, locating them near the loudspeakers is best. Obviously, this approach minimizes the length of the speaker wires and necessitates longer interconnecting cables from the preamplifier to the power amplifiers. The advantage to this strategy lies in the fact that the interconnecting cables carry low-current signals which are more readily transmitted over distances with great accuracy than are the necessarily high current signals required by loudspeakers.

Note that adequate clearance for the AC cord and connecting signal cables must be left behind each N°33. We suggest leaving at least six inches (15 cm) of free space behind each N°33 so that all cables have sufficient room to bend without crimping or undue strain.

Each amplifier should also be placed in such a way that the power switch on the rear panel is easily accessible. This switch disconnects power from even the supervisory power supply, resulting in effective disconnection of the amplifier from the AC mains. (Note that under these conditions, the amplifier cannot respond to remote-turn-on commands, etc.)

Ventilation

Your Mark Levinson N°33 power amplifiers have been designed to complement your listening room visually, with a tall and narrow frontal area which reduces their effective “footprint” and makes them far more presentable than would be the case with a more traditionally proportioned design. As a result, they can be more easily placed beside your loudspeakers. As freestanding units, the N°33 amplifiers normally will have no problem with ventilation.

Each of your N°33 power amplifiers dissipate approximately 800 watts of energy as heat when “at idle.” It is therefore normal and perfectly safe for them to run warm. They do, however, require free air flow around them to allow adequate heat dissipation through air circulation. The top plate and heatsinks of the N°33 must be kept free from any obstruction which would reduce the free flow of air.

If your amplifier must be located inside an enclosure of some sort that restricts airflow, we strongly advise using some fans to increase ventilation through the enclosed space. If the amplifiers become too warm to touch, they are receiving inadequate ventilation. While they are fully protected against overheating, no one enjoys interrupted listening sessions.

Mechanical drawings are included in this manual to facilitate special installations and custom enclosures where necessary (see “Dimensions” at the end of this manual).

Spiking the Amplifier

Once you have established locations for your amplifiers, you may elect to immobilize them by using the four spiked “feet” included with each amplifier. These machined aluminum parts fit snugly over the heavy duty casters on the bottom of each amplifier and provide fixed, rounded points which prevent the amplifiers from rolling about on their casters. Given the weight of the amplifier, sharply pointed spikes are neither needed nor desirable.

If you elect to “spike” your amplifier, enlist the help of another person. Carefully tip the amplifier to one side, toward your assistant (who is supporting it). While the N°33 is balanced on two feet, push a spike over each exposed caster, snugly covering the entire caster assembly. Gently lower the amplifier and repeat the process on the other side.

Operating Voltage

Your Mark Levinson N°33 Reference Monaural Power Amplifier is characterized by its remarkable ability to pass a musical signal with utter integrity, regardless of how demanding that signal and the loudspeakers used might be. When called upon to do so, the N°33 is capable of generating truly prodigious power levels into virtually any speaker load, on either an instantaneous or a continuous basis.

Depending on the demands placed on the N°33 by your loudspeaker and your listening habits, it is possible for the quality and current capability of your electrical service to become the limiting factor in the performance of your system. Given its status as a Reference product, any such limitation (even if only rarely encountered) is unacceptable. As a result, the N°33 has been designed to be capable of taking advantage of dedicated high current AC mains supplies which cannot limit its performance. The N°33 may be ordered in either a High Current (HC) or an Ultra High Current (UHC) configuration, depending on the requirements of any given installation. (*Due to CE regulations, only the UHC, 230V version of the N°33 is available in European Union countries.*)

The UHC configuration of the N°33 accepts a dedicated high voltage (200–240 volts, depending on the country), high current (30–35 amperes, depending on local electrical codes) AC power source. These high current lines are commonly used in residential construction for electric stoves, clothes driers, and other demanding appliances, making their installation fairly routine for any electrical contractor... although this may be the first time your contractor has installed such lines for a stereo system!



Important:

When it comes to high voltage/high current AC wiring such as the N°33 may use, building regulations and electrical codes vary from region to region, and even from one municipality to the next. For this reason, it is impossible for us to anticipate the requirements of your area with regard to high current AC hookups. Please review this section carefully and then contact a local electrical contractor for advice on connecting your N°33 to the AC mains power in your area.

The Mark Levinson N°33 amplifiers may be factory-set for 100V, 120V, 200V, 210V, 220V, 230V or 240V AC mains operation at either 50 or 60Hz. Depending on local electrical codes and regulations, the plug on the supplied AC input module may need to be replaced by a local, licensed electrical contractor. The maximum current requirements at these various voltages under various test conditions are listed in the table shown on the next page.

N^o33 AC mains
current requirements

| | 100V | 120V | 200V | 210V | 220V | 230V | 240V |
|-------------|------|------|------|------|------|------|------|
| Off | <.3 | <.3 | <.2 | <.2 | <.2 | <.2 | <.2 |
| Standby | 2.1 | 1.7 | 1.1 | 1 | 1 | 0.9 | 0.9 |
| On, at idle | 8.4 | 7 | 4.2 | 4 | 3.8 | 3.7 | 3.5 |
| 300w @ 8Ω* | 14.7 | 12.3 | 7.4 | 7 | 6.7 | 6.4 | 6.1 |
| 600w @ 4Ω* | 23.1 | 19.3 | 11.6 | 11 | 10.5 | 10 | 9.6 |
| 1200w @ 2Ω* | 32.5 | 27.5 | 16.5 | 15.5 | 15.0 | 14 | 13.6 |
| 2400w @ 1Ω* | n/a† | n/a† | 31.5 | 30.0 | 28.6 | 27.5 | 26 |

* power ratings are continuous (rms) with less than 0.5% THD, from 20-20,000 Hz.
 † not applicable, since continuous current requirements exceed available AC mains service.

It is important to understand that these are worst-case requirements under severe test conditions, which are extremely unlikely to be encountered in normal use. The power demands that a single N^o33 might conceivably make when being used to reproduce music with actual loudspeakers are substantially lower, safely within the normal abilities of 100V and 120V, 15 ampere lines. Still, for the best possible performance with extremely difficult loads, we recommend installing a dedicated AC line for each amplifier of at least 200-volt and 30-ampere capability.

The operating voltage of the N^o33 cannot be changed by the user, and any attempt to do so will void the warranty. If you need to change the operating voltage of your N^o33 power amplifiers, or if the voltage indicated on the rear panel label is not available in your area, contact your Mark Levinson dealer for assistance.

N^o33 rear-panel label

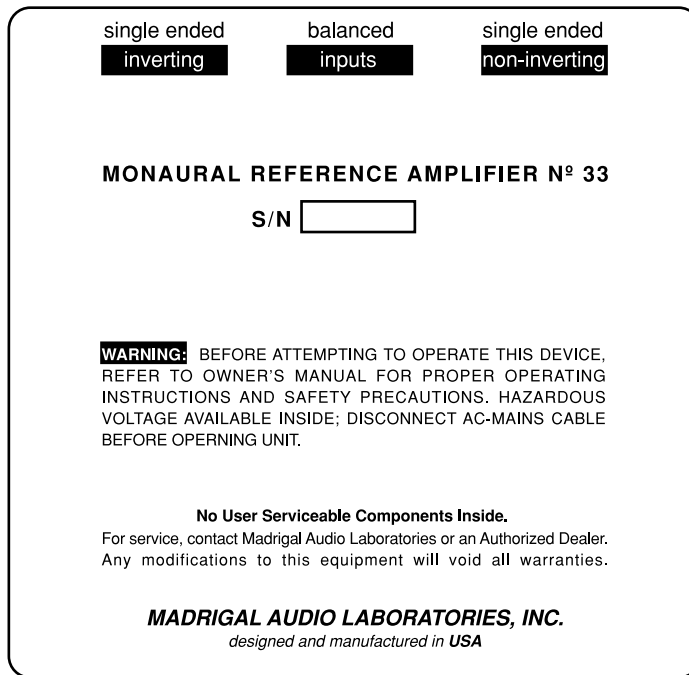

Special Design Features

Congratulations on your purchase of Mark Levinson N°33 Reference Monaural Power Amplifiers. While your new amplifiers are straightforward in their everyday use, they include several design features which are responsible for their outstanding performance. In particular, the N°33 Reference Monaural power amplifiers defy the accepted wisdom that it is impossible to design a large, powerful amplifier that also has all of the finesse of the finest smaller amplifiers. A few of the technical highlights that make this possible are given below.

Massive Power Supply

The N°33 incorporates two 2.45 kVA low noise toroidal transformers in a fully balanced power supply. In this design, there is a separate power supply (each with its own power transformer) for both the inverting and non-inverting halves of the amplifier. Twelve 39,000 μF low ESR capacitors are used in each amplifier. The power supply of each N°33 provides almost $\frac{1}{2}$ a Farad of capacitance and 1200 Joules of energy storage.

Heavy oxygen-free copper bus bars enhance the efficiency of power distribution within the amplifier and eliminate variances introduced by the wiring harnesses, etc. more commonly found even in high performance amplifiers. High frequency power supply bypass is accomplished on individual PC boards by a total of 56 components of several film types. The resulting uniformly low power supply impedance seen by the various circuits within the N°33 lays the foundation for both the massive power and the extraordinary finesse that characterizes this amplifier.

AC Regeneration

In recent years, the detrimental sonic effects of noisy, unbalanced AC mains supplies have become widely known. Various passive AC “line conditioners” are available for use with line level components such as preamplifiers and digital audio processors to address these problems. In most cases, these line conditioners provide some filtering of the AC mains, along with some measure of surge protection. None of these devices may be used to good effect with power amplifiers, however, since they cannot handle the large instantaneous currents which power amplifiers require during normal operation. In effect, passive line conditioners become a “bottleneck” in the otherwise free flow of power through the amplifier to the speakers, reducing dynamic impact and musicality.

In the N°33, a more sophisticated approach is used that provides greater line conditioning benefits than the commercially available passive devices can hope to provide, while simultaneously avoiding any performance “bottlenecks.”

A distortion-free 60 Hz sine wave is regenerated within the N°33, and then used to power a separate power supply dedicated to all the voltage gain stages. AC power is delivered from the wall to the primary supply of the N°33, where it is rectified, filtered and regulated into positive and negative DC voltages. A portion of this DC power is then used to drive an oscillator circuit which regenerates a pure 60 Hz sine wave without any of the noise or contamination so common to the AC mains as delivered to our homes by power utilities.

The regenerated, pure sinusoidal AC wave is then sent to a dedicated secondary power supply, where it is converted to positive and negative DC power to be used by all of the voltage gain stages. This dedicated supply for voltage gain stages benefits from having a truly balanced source (unlike the dissimilar imped-

ances of AC mains line and neutral), as well as from the total elimination of AC mains fluctuations and noise. As a result, the critical voltage gain stages of the N°33 operate in a highly optimized environment, and are able to pass along *significantly* more low-level resolution and detail in the musical signal that they amplify.

Fully balanced design

A truly balanced input topology eliminates the need for an input buffer amplification stage and allows the first stage differential amplifier to be driven directly by the source. Matched impedances are presented to the source and both signals travel through identical circuit paths. Voltage gain is implemented on a cyanate ester circuit board for superior sonic performance and consistency.

Painstaking attention to layout of the amplifier was essential to minimize magnetic field distortions possible with such a massive power delivery system, including careful mirror-imaging of circuits to cancel magnetic fields. Balanced output is accomplished through the use of two identical amplifiers. A balanced input signal remains balanced throughout the N°33. Rejection of common mode noise and distortion is obtained when the two halves finally meet: in the loudspeaker's voice coil.

True Voltage Source

The N°33 power amplifier operates as a virtually perfect textbook case of a “voltage source.” This is to say that the N°33 will maintain whatever the appropriate voltage might be at any moment (given the demands of the music) without any particular regard for the current demands of the loudspeaker. Whether the loudspeaker requires one amp or one hundred amps of current at that instant, the N°33 will deliver it.

Because of this “voltage source” characteristic, the N°33 doubles its power output every time the loudspeaker impedance is cut by half. Its continuous rated power is 300 watts at 8 Ω ; 600 watts at 4 Ω ; 1200 watts at 2 Ω ; and 2400 watts at 1 Ω —assuming the electrical circuit in the wall can support these extraordinary power levels. A 1 Ω test at continuous maximum power requires about 62 amperes at 120V and 31 amperes at 240V. (The laws of physics refuse to be cheated. Long-term, you cannot deliver more power into the speaker than you can pull from the wall.)

Sixty TO-3 output transistors are distributed in the four main heatsinks of each N°33 to conduct and control the flow of its prodigious power capabilities to the loudspeaker. There are fifteen complementary pairs of output transistors in each of two output stages (inverting and non-inverting) within each amplifier.

No known loudspeaker can absorb the *continuous* full power capability of the N°33. (Nor would you want to be present in the room were you to find one that could do so.) However, many high quality loudspeakers may require these rather extreme power levels on a *short term* basis when reproducing music at realistic levels. The N°33 can answer these needs with impunity, without any power supply “sag” and without altering its sonic performance in any way. Its resultant imperturbable nature is reflected in the authority and control with which it reproduces music.

Extensive Protection

Your N°33 power amplifiers will shut themselves down if they sense any of a number of fault conditions which could cause damage to either themselves or to your loudspeakers. These fault conditions include

- the presence of DC (direct current) at the output
- either over-voltage or under-voltage conditions on the AC mains
- unsafe operating temperatures in any of several critical areas within the amplifier
- sustained output current in excess of 80 amperes (which would occur only in the event of a dead short across the outputs).

If any of these fault conditions is sensed while the amplifier is in either standby or fully on, the amplifier will shut down completely (off mode, not merely standby). Moreover, it will not turn on again until the fault condition is corrected.

In addition, the AC input to each transformer is fused to protect against excessive current conditions such as driving shorted outputs. In-rush limiting prevents premature aging of power supply components during power-up, and switches off-line once the power supply has been charged.

Finally, the N°33 incorporates a controlled clipping circuit that prevents the output devices from saturating. The harsh high frequency harmonics generated by hard-clipped output devices are avoided by the waveshaping action of this controlled clip circuitry.

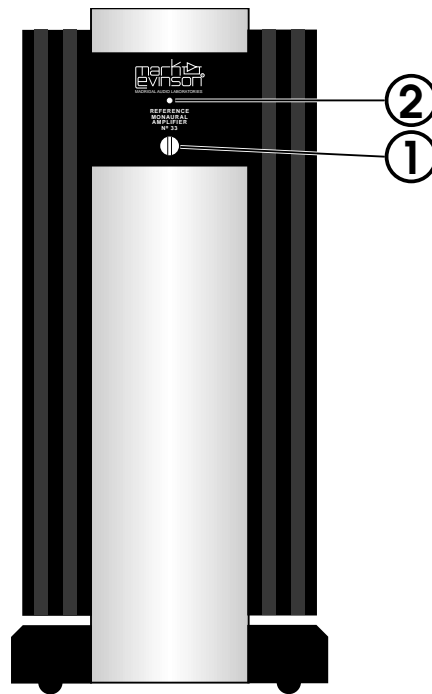

Front Panel

1 STANDBY BUTTON

When power is first applied to the N°33 power amplifier, and assuming the **rear panel AC mains switch** is set to its **on** position, the amplifier remains completely **off**. Pressing the front panel **standby button** will bring the amplifier from completely **off** to **standby**. After a delay of ten seconds (to allow all circuitry to stabilize), subsequent pressing of the power button will toggle the N°33 between **standby** mode and fully **on**. Power consumption of the N°33 when fully **on** and at idle is approximately 600 watts.

To turn the amplifier completely **off**, press and hold the **standby button** for approximately one second, until the front panel **indicator light** turns off.

2 INDICATOR LIGHT

The **indicator light** shows the operational status of your N°33:

Full brightness indicates that the N°33 is **on** and ready to be used.

Blinking slowly indicates the unit is in **standby**.

Dimly lit indicates that the main power supply is completely off, leaving only the supervisory supply operational.

Completely off indicates that the **rear panel AC mains switch** has been turned off, disengaging even the supervisory power supply.

If the amplifier will not turn on, you may want to check the **rear panel AC mains switch**, your AC connections, or have your dealer inspect the rear-panel fuses (which are *not* user-serviceable).

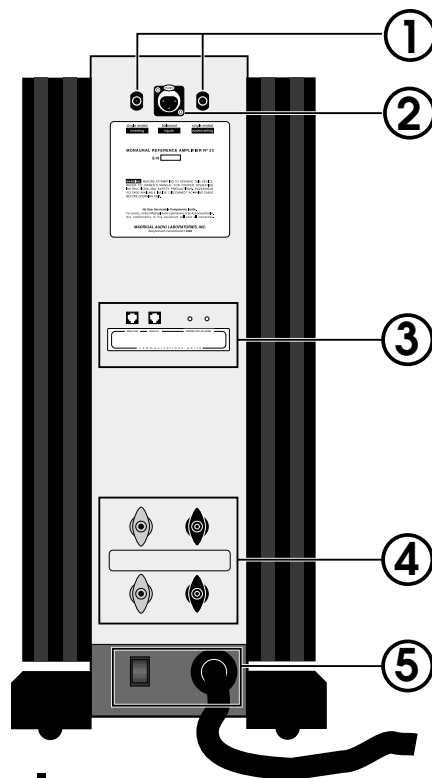

Rear Panel



Caution!

Turn the volume on your preamplifier all the way down before attempting to connect anything to your Mark Levinson N°33.

1 SINGLE-ENDED INPUTS

These RCA connectors accept single-ended inputs from preamplifiers with single-ended (RCA) outputs. Both inverting and non-inverting inputs are provided. Single-ended input signals are converted to balanced signals immediately upon being received at the N°33, and are handled as balanced signals thereafter.

If your preamplifier does not support balanced connection to the power amplifier, connect the single-ended output of your preamplifier to the non-inverting RCA input on the N°33. Repeat this process for the other N°33(s) in your system, being certain to be consistent throughout. To reduce the chance of noise pickup at the (otherwise unterminated) inverting input, short the inverting input of each amplifier by inserting the provided U-shaped shorting strap between pins #1 and #3 of the XLR connector to reduce the chance of noise pickup at the (otherwise unterminated) input. (As delivered from the factory, this shorting strap is already installed.)

Important!

If you use single-ended interconnection with the N°33, you must take care to use one input or the other (inverting or non-inverting) consistently throughout your system. If you mix their

use, the amplifiers will operate out of phase with each other, resulting in a loss of bass and poor imaging.

Although the best form of balanced interconnection is via a balanced cable and XLR connectors, it is possible to operate the N°33 in a balanced configuration by using both inverting and non-inverting RCA inputs simultaneously. This approach is generally less desirable, however, since separate single-ended cables will be more susceptible to noise pickup than a single balanced cable. If this approach is taken, you must remove the shorting strap from the XLR input. Save it for possible use at a later date.

2 BALANCED AUDIO INPUT

Accepts a signal from a preamplifier with balanced outputs via a high quality XLR connector. If connection to the preamplifier is made with a balanced interconnecting cable, it is important to remove the shorting plug from between pins #1 and #3 of the XLR input which was placed there prior to shipment from the factory. Save it for possible use at a later date.

The pin assignments of this XLR-type female input connector is:



- Pin 1: Signal ground
- Pin 2: Signal + (non-inverting)
- Pin 3: Signal – (inverting)
- Connector ground lug: chassis ground

These pin assignments are consistent with the standards adopted by the Audio Engineering Society. Refer to the operating manual of your balanced-output preamplifier to verify that the pin assignments of its output connectors correspond to your Mark Levinson N°33. If not, wire the cables so that the appropriate output pin connects to the equivalent input pin.

3 COMMUNICATIONS LINK AND REMOTE TURN-ON INPUTS

The N°33 may be controlled by a “linked” Mark Levinson 30-series preamplifier when the **slave in** communications port is connected to the **master** port of the preamplifier. Subsequent N°33 amplifiers may be “daisy chained” from the first N°33’s **slave out** to their **slave in** port, up to a maximum of six amplifiers total.

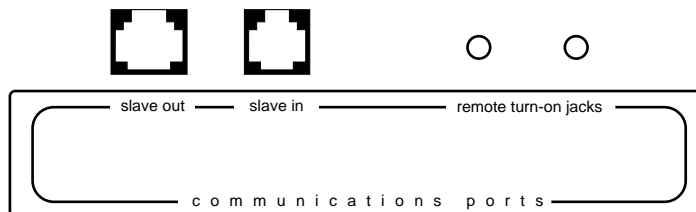

A “straight-through,” six conductor Link cable with six-conductor modular connectors on both ends is used to connect the preamplifier to the first power amplifier. Such a cable is made (counter-intuitively) by incorporating a 180° twist into the cable before terminating it, as shown below:

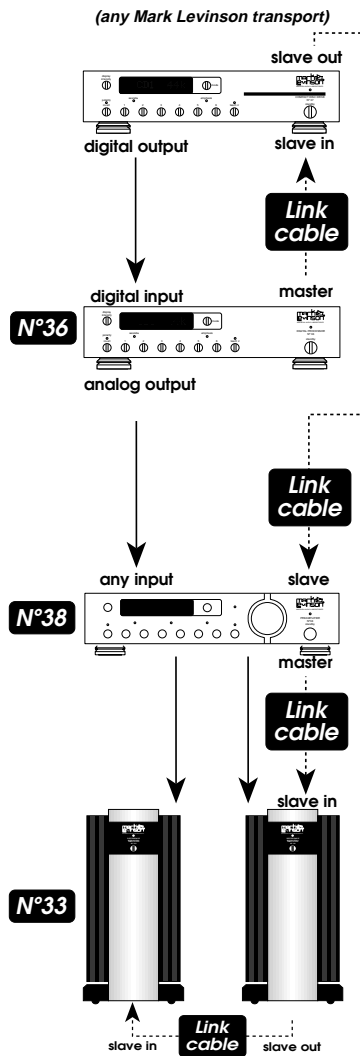

Remote turn-on
tip polarity

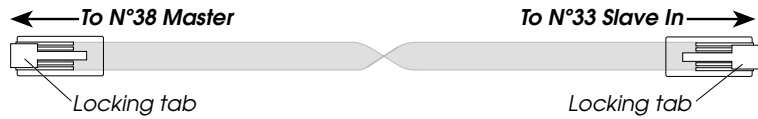

A different Link connector configuration is used for the “daisy-chain” of one amplifier to the next, to minimize the opportunity for mis-wiring. In effect, this cable is identical to the one between preamplifier and power amplifier except that it uses pins 1 through 6 of an eight-conductor modular connector at one end, as shown below:

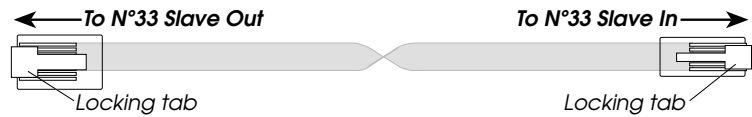

(Note that the pins are numbered 1 through 8 from left to right when the locking tab is down and the metal contacts are pointing away from you.)

When connected in this manner, the power amplifiers will be toggled between **standby** and fully **on** when the preamplifier goes between **standby** and fully **on**. In addition, should a fault condition cause the amplifier’s protection circuitry to activate, the N°33 can report the nature of the problem to a linked Mark Levinson preamplifier via this communications link. If this occurs, the preamplifier will display the number of the amplifier at fault (AMP1 being the first amplifier in the daisy chain, AMP2 being the second amplifier, and so on). The preamplifier will also indicate the nature of the fault condition with one of the following codes:

| Code | Fault Condition |
|------|--------------------------|
| HOT! | thermal shutdown |
| DCO! | uncorrectable DC offset |
| ZAP! | excessive output current |

Additional remote turn-on jacks provide compatibility with a wide range of products, to facilitate remote turn-on and turn-off in systems which do not include a Mark Levinson 30-series preamplifier (which would normally use the Mark Levinson Communications Link described above). These 1/8" (3.5 mm) “mini-jacks” allow other components to bring the N°33 power amplifiers in and out of **standby**. Two such mini-jacks are provided to allow “daisy-chaining” of multiple amplifiers. When “daisy-chaining” multiple amplifiers, the last mini-jack in the chain must be terminated with a dummy 1/8" plug [that is, an empty plug must be inserted into the 1/8" (3.5 mm) jack].

This remote “trigger” will be operated by a 3–12 volts DC positive-polarity pulse, of at least 100 milliseconds duration, with tip polarity as shown below:

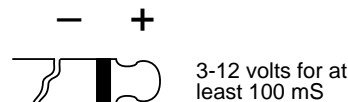

Your Mark Levinson dealer can help you take advantage of these design features to maximize your system's versatility.

4 SPEAKER BINDING POSTS

The Mark Levinson N°33 is equipped with custom made, gold-plated, high-current binding posts for output termination to a loudspeaker system. To take full advantage of the N°33's sonic quality, we recommend using high-quality speaker cable; see your Mark Levinson dealer.



Caution!

NEVER connect the Mark Levinson N°33 output terminals to any device other than a loudspeaker.
NEVER short-circuit the amplifier's output terminals.
NEVER connect the output terminals of one amplifier to the output terminals of another amplifier.

We recommend connecting speaker cables to the Mark Levinson N°33 by means of a high-quality spade lug or hook lug, soldered to the cable (or crimped with extremely high pressure).



Spade lug

Hook lug

Connect a + (positive or red) output post of the Mark Levinson N°33 to the + (positive or red) input terminal of the appropriate loudspeaker. [If biwiring, repeat using the other + (positive or red) output post of the amplifier and the + (positive or red) input terminal of the loudspeaker.]

Connect a – (negative or black) output post of the N°33 to the – (negative or black) input terminal of the appropriate loudspeaker. [If biwiring, repeat using the other – (negative or black) output post of the amplifier and the – (negative or black) input terminal of the loudspeaker.]

5 AC MAINS CORD AND AC MAINS SWITCH

Conventional IEC standard power cords cannot be used in the N°33, due to the potential current requirements of N°33 when operating into low impedance loads. (The highest available current rating for an IEC standard three-conductor connector such as is used on most stereo equipment, including other Mark Levinson products, is 16 amperes.) Instead, the N°33 incorporates a high current AC cord which is attached directly to the amplifier itself via a specially-designed AC mains module, located at the bottom of the rear panel. A high current AC connector is included with the N°33 and may be attached to the end of the AC mains cord.

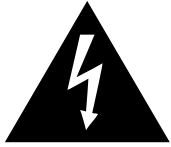

Warning!

High current AC wiring regulations vary from one location to another—do not attempt to connect the N°33 to your AC mains power without consulting a qualified local electrical contractor. (See Operating Voltage in this manual for more information.)

The Mark Levinson N°33 has been safety-tested and is designed for operation with a three-conductor power cord. Do not defeat the “third pin” or earth ground of the AC power cord.

An **AC mains switch** is located adjacent to the power cord on the rear panel of the amplifier. This switch may be used to disconnect the supervisory power supply from the AC mains without having to actually unplug the amplifier from the wall outlet. Since this small supervisory supply controls the main power supply’s access to AC power, shutting down the supervisory power supply also disconnects the main supply from AC. If you plan to be away for an extended period, or have any other reason to turn the amplifier completely off, you may use the **AC mains switch**.



Note:

When first connected to the AC mains, the amplifier normally draws a small amount of power which is used to control the power-up sequence. Turning this rear panel switch “off” disconnects even this small power supply; you must turn this switch back “on” before you can enter the power-up sequence described in Front Panel, item #2, or before the amplifier will respond to a remote turn-on command.

Two slo-blow 35 ampere fuses are located inside the N°33, on the AC mains module. The protection circuitry of the N°33 has been designed such that only a catastrophic failure could cause these fuses to blow. As a result, if you suspect that your AC fuses have blown, disconnect the N°33 from the AC mains and contact your Mark Levinson dealer for assistance. Do not attempt to replace these fuses yourself.



Danger!

Potentially dangerous voltages and current capabilities exist within the N°33 power amplifier, even when disconnected from AC mains. Do not attempt to open any portion of the N°33’s cabinet.

There are no user-serviceable parts inside the N°33 power amplifier. All service of this product must be referred to a qualified Mark Levinson dealer or distributor.

Care & Maintenance

To remove dust from the cabinet of the N°33, use a feather duster. To remove dirt and fingerprints, we recommend isopropyl alcohol and a soft cloth. Apply the alcohol to the cloth first and then lightly clean the surface of the N°33.



Caution!

At no time should liquid cleaners be applied directly to the N°33, as direct application of liquids may result in damage to electronic components within the unit.

U.S. and Canadian Warranty

90-Day Limited Warranty

This Mark Levinson® product is warranted to be free from defects in material and workmanship under normal use for a period of ninety (90) days from the date of purchase. **To extend the warranty of this Mark Levinson product**, return the warranty registration card along with a copy of the original receipt of purchase to Madrigal Audio Laboratories, Inc., P. O. Box 781, Middletown, CT 06457.

Five Year Extended Warranty

The **extended warranty** for this Mark Levinson product is **five (5) years** from the date of purchase. During the warranty period, any Mark Levinson component exhibiting defects in materials and/or workmanship will be repaired or replaced, at our option, without charge for either parts or labor, at our factory. The warranty will not apply to any Mark Levinson component that has been misused, abused or altered.

Any Mark Levinson component not performing satisfactorily may be returned to the factory for evaluation. Return authorization must first be obtained by either calling or writing the factory prior to shipping the component. The factory will pay for return shipping charges only in the event that the component is found to be defective as above mentioned. There are other stipulations that may apply to shipping charges.

There is no other express warranty on this component. Neither this warranty nor any other warranty, express or implied, including any implied warranties of merchantability or fitness, shall extend beyond the warranty period. No responsibility is assumed for any incidental or consequential damages. Some states do not allow limitations on how long an implied warranty lasts and other states do not allow the exclusion or limitation of incidental or consequential damages, so that the above limitation or exclusion may not apply to you.

This warranty gives you specific legal rights, and you may also have other rights which vary from state to state. **This warranty is applicable in the United States and Canada only.** Outside of the U.S. and Canada, please contact your local, authorized Mark Levinson distributor for warranty and service information.

Obtaining Service

We take great pride in our dealers. Experience, dedication, and integrity make these professionals ideally suited to assist with our customers' service needs.

If your Mark Levinson component must be serviced, please contact your dealer. Your dealer will then decide whether the problem can be remedied locally, or whether to contact Madrigal for further service information or parts, or to obtain a Return Authorization. The Madrigal Technical Services Department works closely with your dealer to solve your service needs expediently.



Important!

Return authorization must be obtained from Madrigal's Technical Services Department BEFORE a unit is shipped for service.

It is extremely important that information about a problem be explicit and complete. A specific, comprehensive description of the problem helps your dealer and the Madrigal Technical Services Department locate and repair the difficulty as quickly as possible.

A copy of the original bill of sale will serve to verify warranty status. Please include it with the unit when it is brought in for warranty service.



Warning!

All returned units must be properly packaged (preferably in their original packing material), and the proper return authorization numbers must be marked on the outer carton for identification. If the packaging to protect the unit is, in our opinion or that of our dealer, inadequate to protect the unit, we reserve the right to repackage it for return shipment at the owner's expense. Neither Madrigal nor your dealer can be responsible for shipping damage due to improper (that is, non-original) packaging.

Your dealer can order a new set of shipping materials for you if you need to ship your component and no longer have the original materials. There will be a charge for this service. We *strongly* recommend saving all packing materials in case you need to ship your unit some day.

Specifications

The correlation between published specifications and performance is unreliable. A list of numbers reveals virtually nothing. All technical measurements must be subject to qualitative as well as quantitative interpretation. Measurements of the Mark Levinson N°33 yield excellent results by any standards. However, only those specifications that apply to its actual operation are included here. All specifications are subject to change at any time, in order to improve the product.

- **Rated power output:** 300 w/ch continuous rms power @ 8Ω
600 w/ch continuous rms power @ 4Ω
1200 w/ch continuous rms power @ 2Ω
2400 w/ch continuous rms power @ 1Ω
*all of the above power ratings measured from
20 Hz–20 kHz with no more than 0.3% THD*
- **Frequency response:** within 0.1 dB from 20 Hz to 20 kHz
- **Signal to Noise ratio (main outputs):** better than –80 dB (ref. 1 w)
- **Input impedance:** 100kΩ (balanced)
50kΩ (single-ended)
- **Voltage gain:** 26.8 dB
- **Input sensitivity:** 2.3 V for full rated output
- **Power consumption:** typically 840 W (±5%) at idle
typically 210 W (±5%) in standby
- **Mains voltage:** determined by the needs of country for which
the unit was manufactured; cannot be reset by dealer or user
- **Overall dimensions:** See “Dimensions”
- **Shipping weight:** 435 lbs. (198 kg) each
- **Connector complement:** four custom binding posts per channel
one 3-pin XLR balanced input connector per channel
two RCA input connectors per channel
two 1/8" mini-jacks for remote turn-on
two Mark Levinson communications ports (RJ-11)
one captive high current AC mains cord
- **Output impedance:** less than 0.05Ω from 20–20,000 Hz

For more information, see your Mark Levinson dealer, or contact:

Madrigal Audio Laboratories, Inc.

P.O. Box 781

2081 South Main Street (Route 17)

Middletown, Connecticut 06457 USA

Telephone (860) 346-0896

FAX (860) 346-1540

Dimensions: N°33

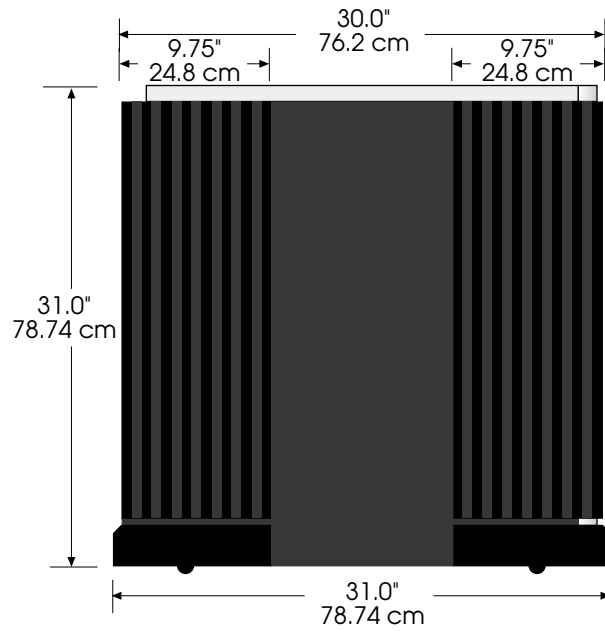
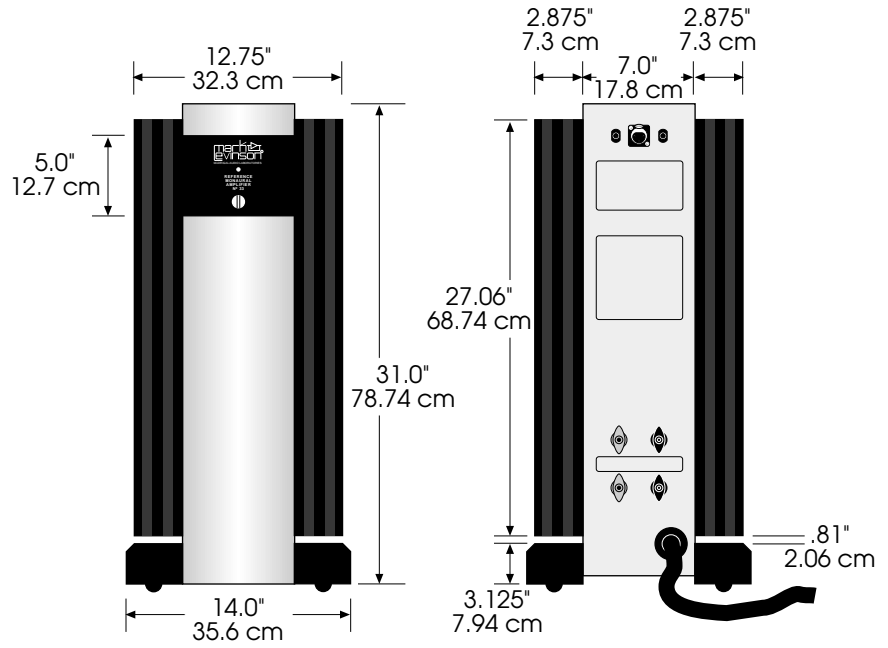



MADRIGAL

Madrigal Audio Laboratories, Inc.
2081 South Main Street, P.O. Box 781
Middletown, Connecticut 06457 USA

Telephone: (860) 346-0896
Fax: (860) 346-1540
<http://www.madrigal.com/>

mark
evinson[®]

MADRIGAL AUDIO LABORATORIES

is a registered trademark of Madrigal Audio Laboratories, Inc.

H a Harman International company